

EGBike

BICYCLE OWNER'S MANUAL

READ THIS BOOK BEFORE USING YOUR NEW BICYCLE

EGBike

- You have chosen one of the finest bicycles available. Your bicycle has been carefully manufactured with the benefit of years of experience and fully tested to ensure the highest standards of safety and comfort for the rider. In order to fully enjoy your bicycle, a certain amount of care and maintenance is required. This Owner's Manual is not intended as a fully comprehensive workshop manual but it will guide you safe usage and correct maintenance of your new bicycle. Please read the Manual thoroughly, paying special attention to the safety warnings. This Manual will help ensure that your new bicycle keeps working properly and safely, and continues to give you years of enjoyable cycling.

EG Bike

CONGRATULATIONS



PART 1

Parts Identification

Pages 1 - 3



PART 2

Assembly

Pages 4 - 12



PART 3

Before You Ride

Pages 13 - 27



PART 6

Purchase Record

Page 69



PART 5

Detailed Maintenance

Pages 31 - 67



PART 4

Servicing

Pages 28 - 30



PART 7

Warranty

Inside Back Cover



PART 8

Contact Addresses

Back Cover



Warning/Important

(Take notice of this symbol throughout this manual)

1. PARTS IDENTIFICATION	1	. pedalling technique	14	. how to fix a flat tyre	30
Mountain Bicycles & Crossbikes	1	. hill technique	15	. tyre valves	31
BMX/Loop Frame/U-Frame Bicycles	2	. cornering technique	15	Handlebars & Fork	32
		. rules for children	15	. handlebar stem	32
		Gears . How To Operate	16	. handlebars	33
2. ASSEMBLY	3	. derailleur gears	16	. headset	34
Single Geared Bicycles	3	. operating principles	16	Saddle & Seat Post	36
		. thumb shifters (top mounted)	17	Brakes	38
		. below the bar shifters	18	. v-brake	39
		. hand grip shifters	18	. cantilever calipers	40
3. BEFORE YOU RIDE	7	Bicycle Care	19	Drivetrain	42
Correct Frame Size	7	. basic maintenance	19	. Pedals	42
Riding Position	8	. storage	19	. Crank Set	44
. saddle height	8	. security	20	. one piece cranks	45
. reach	8	4. SERVICING	21	. cotterless cranks	46
. handlebar height	9	. Schedule 1 . Lubrication	21	. Chain	48
Safety Checklist	10	. Schedule 2 . Service Checklist	22	. freewheel	49
. brakes	10	Torque Requirements	23	. coaster hub	50
. wheels & tyres	10	Tools Required	23	Derailleur Systems	51
. steering	10	5. DETAILED MAINTENANCE	24	. rear derailleur	52
. chain	11	Wheels and Tyres	24	. front derailleur	54
. bearings	11	. wheel inspection	24	Reflectors	55
. cranks & pedals	11	. tyre inspection	25	Accessories	56
. derailleurs	11	. recommended tyre pressures	25	Troubleshooting	59
. frame & fork	11	. front wheel removal & replacement	26	6. PURCHASE RECORD	62
. accessories	11	. rear wheel removal & replacement	27		
Helmets	12	. correct QR axle setting	28		
Riding Safely	13	. hub bearing adjustment	29		
. general rules	13				
. wet weather riding	14				
. night riding	14				



Mountain Bicycles & Crossbikes . Mountain bicycles are designed to give maximum comfort over a wider variety of road surfaces. The wider handlebars and convenient shift lever position make them very easy to control. Wider wheel rims and tyres give them a softer ride with more traction on rough surfaces. The frame and fork on mountain style bicycles is much sturdier and heavier than a racing style bicycle. A variation of the mountain bicycle is the crossbike or hybrid. This style of bicycle is lighter than a mountain bicycle but not as fast as a racing bicycle. It combines some of the features of comfort and control with lighter weight and higher speed.

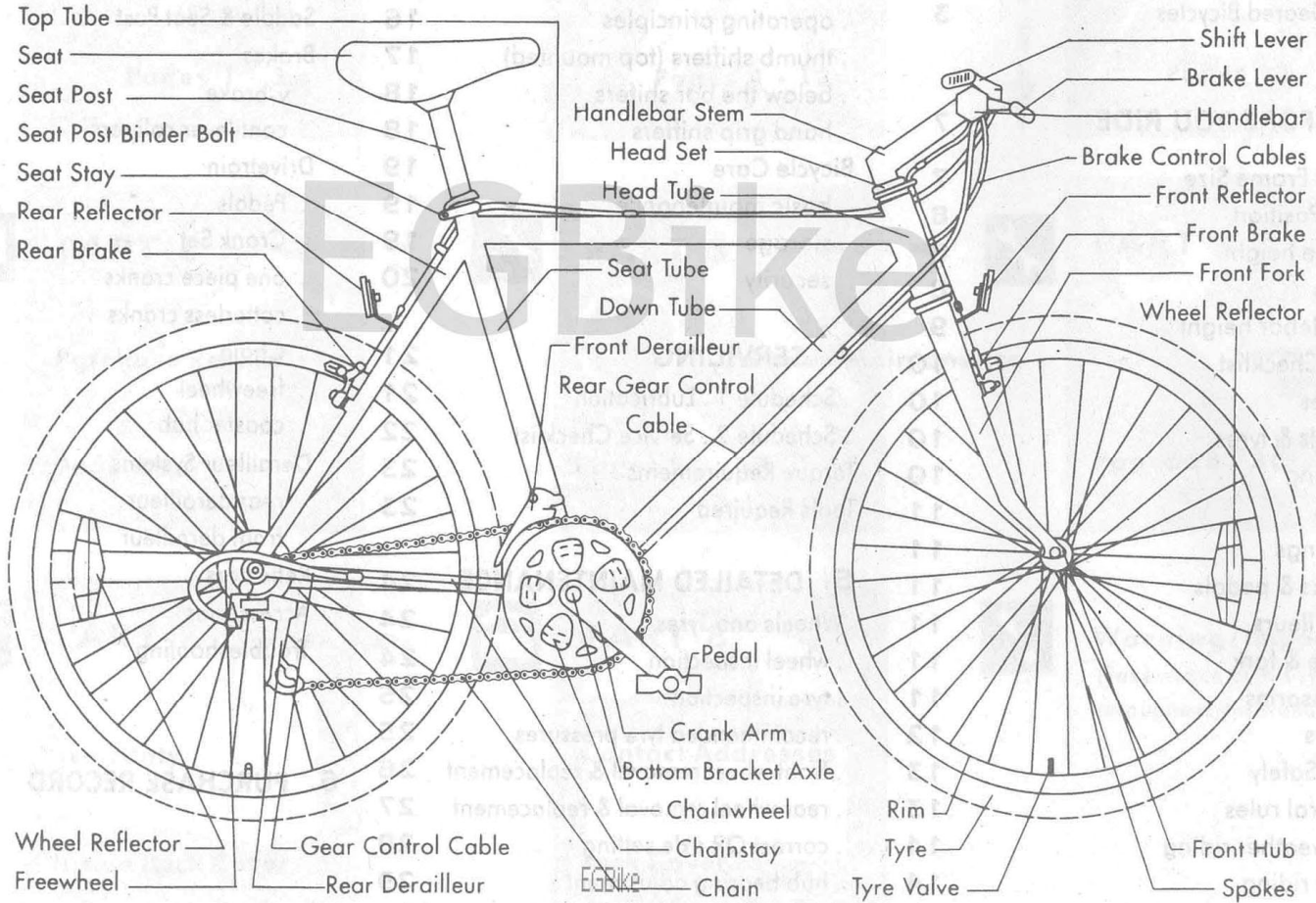

BMX Bicycles . BMX style bicycles are a popular general purpose type most suited to younger riders.

They are valued because of their sturdy and simple construction and low maintenance.

Other kinds of children's bicycles use different styles of frames such as the loop frame and the U-shape frame.

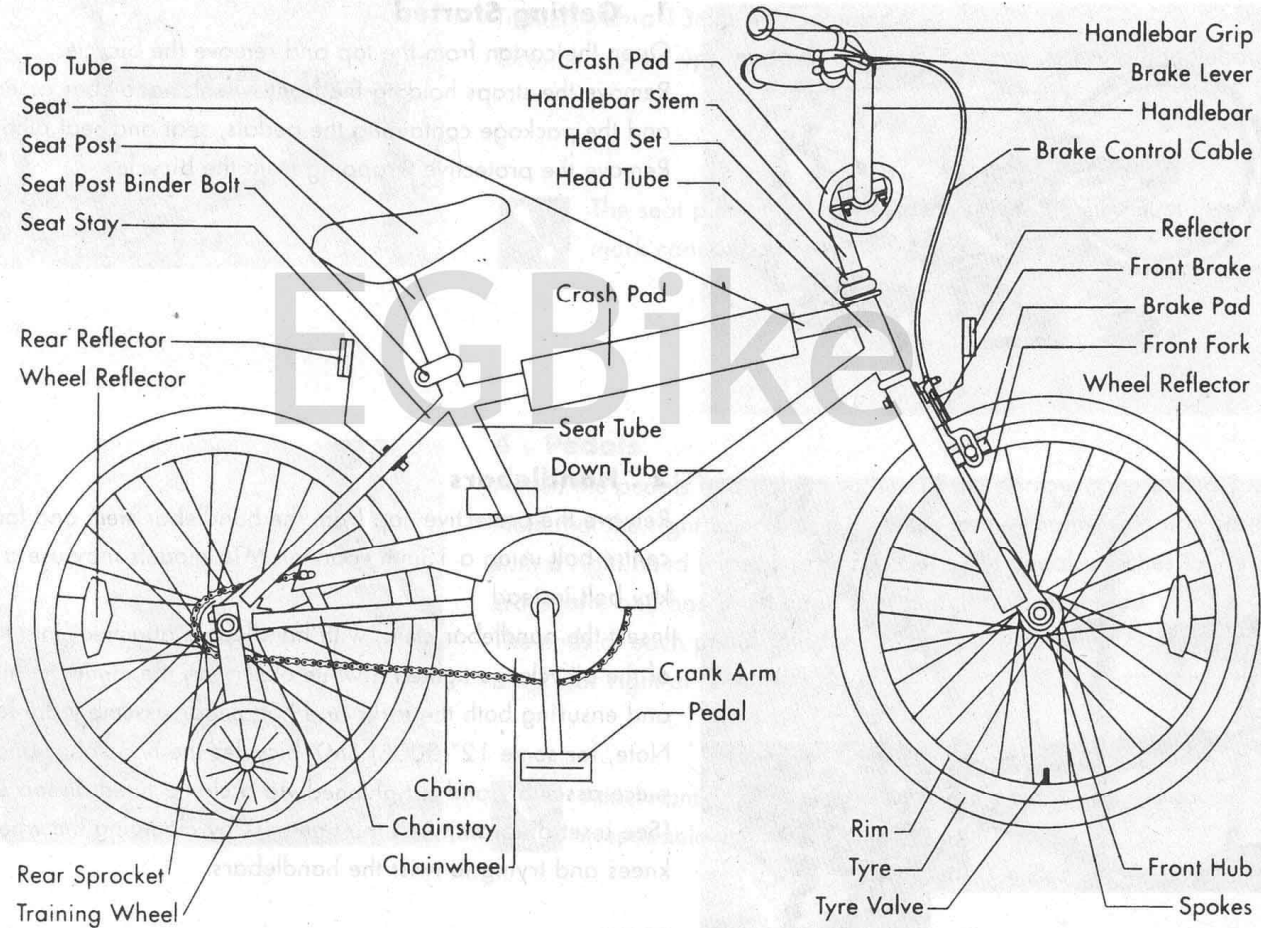



SINGLE SPEED BICYCLES

Includes 12"(30cm), 16"(40cm) and 20"(51cm) wheel BMX and MTB style bicycles, 16"(40cm) and 20"(51cm) U-Frame and Loop Frame bicycles. Assembly is the same for girls and boys models.

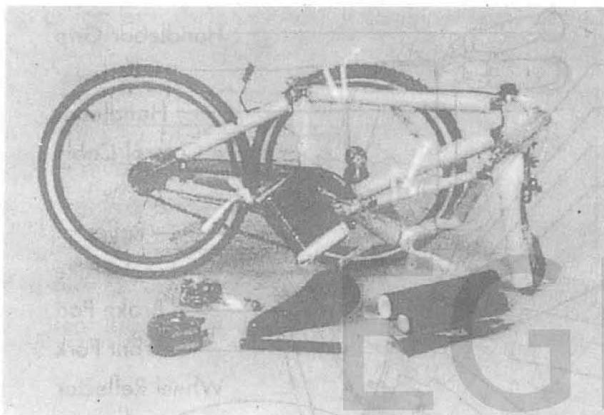

1 . Getting Started

Open the carton from the top and remove the bicycle.
Remove the straps holding the front wheel, handlebar assembly, and the package containing the pedals, seat and seat pillar.
Remove the protective wrapping from the bicycle.



2 . Handlebars

Remove the protective cap from the handlebar stem and loosen the centre bolt using a 13mm spanner. MTB models may use a 6mm Allen key bolt instead

Insert the handlebar stem, with handlebars attached, into the head tube of the bicycle, re-tighten it while observing the minimum insertion mark and ensuring both the forks and handlebar assembly are facing forward. Note, for some 12"(30cm) BMX bicycles the handlebar and stem is a one piece assembly and is tightened via a clamp fitted on top of the fork tube. (See inset diagram). Test the tightness by clamping the wheel between your knees and trying to twist the handlebars.



The handlebar stem must be inserted so that the minimum insertion mark cannot be seen.

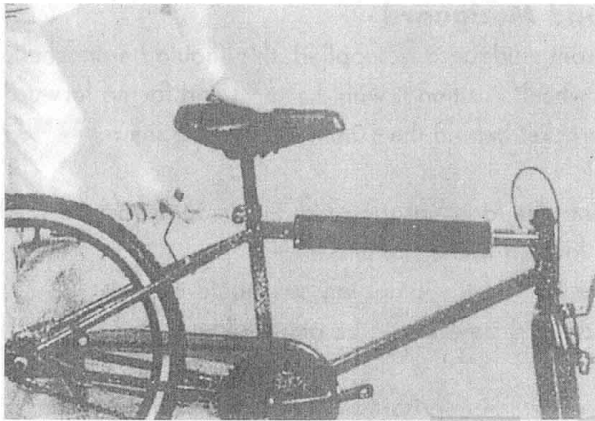

3 . Seat

Insert the seat pillar into the seat clamp and tighten.

Insert the seat/pillar assembly into the frame tube of the bicycle observing the minimum insertion mark on the pillar.

Tighten with a 13mm ring spanner.

Turn the bicycle upside down and rest it on the seat and handlebars.



The seat pillar must be inserted so that the minimum insertion mark cannot be seen.

EGBike

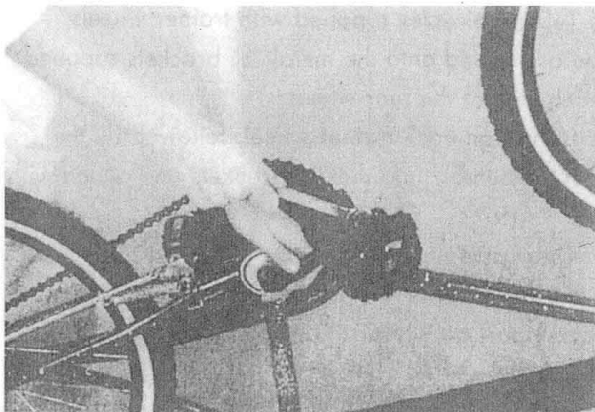

4 . Pedals

Attach the pedals and tighten with a 15mm narrow open ended spanner.

Note that the right hand pedal attaches to the chainwheel side crank with a right hand (clockwise) thread. The left pedal attaches to the other crank arm and has a left hand (counter clockwise) thread.

The ends of each pedal spindle are marked with either an 'R' for right or 'L' for left.



Attachment of an incorrect pedal into a crank arm will cause irreparable damage.



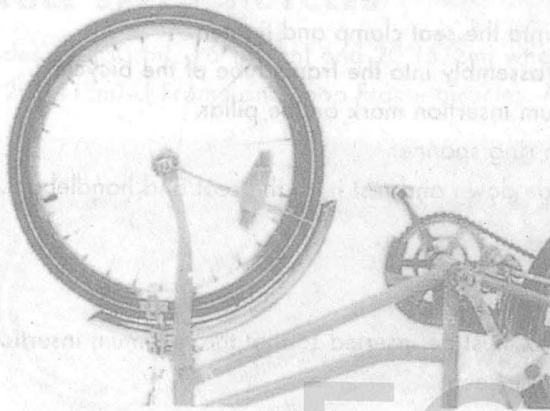

5 . Front Wheel and Mudguard

For bicycles where a front mudguard is supplied, this should be attached before fitting the front wheel. Position it with the short end facing forward and attach the metal bracket behind the 10mm nut fixed to the rear of the brake centre bolt.

Insert the front wheel into the forks ensuring that the small tab on the washer under the wheel nut is located in the slot in the forks.

This tab will ensure that the wheel will not fall out should the nuts become loose. The mudguard stays are to be attached under the wheel axle nuts.

Tighten the wheel nuts using the appropriate 14mm or 15mm spanner.

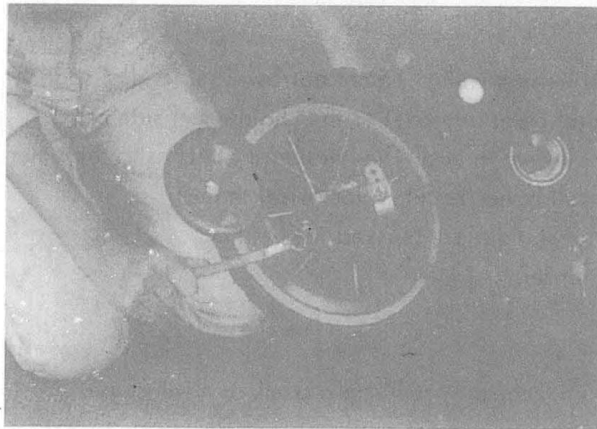

6 . Training Wheels

For 12"(30cm) and 16"(40cm) bicycles supplied with trainer wheels, each wheel must first be assembled onto the metal "L" brackets supplied, and then mounted to each side of the rear wheel.

First, insert the axle bolts through each trainer wheel, followed by the washers. Next, insert each assembly into the "L" brackets and attach with the hexagonal nuts supplied.

Then, remove the 15mm rear axle nuts from the bicycle and fit the metal locating brackets onto the rear axle so that the tabs fit into the frame slot. Place the training wheel support arms over the locating brackets, refit and re-tighten the rear axle nuts.

Note that the trainer wheels should be positioned so that they do not quite touch the ground when the bicycle is standing vertically.

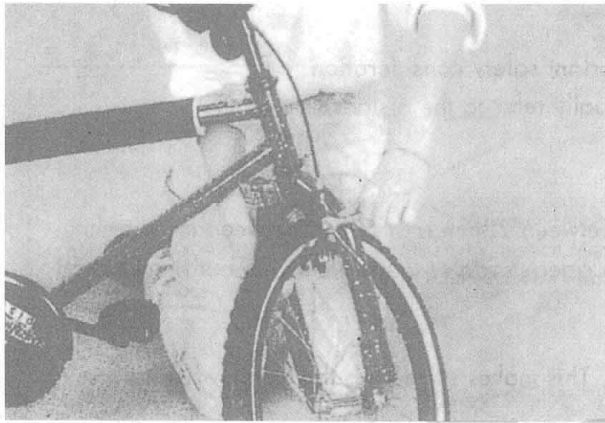

7 . Front Brake

Turn the bicycle upright using the kickstand, if provided, to support it. To connect the front brake, position yourself to the left of the bicycle as shown.

With your right hand, grasp the brake caliper and squeeze it firmly so that the brake pads are touching the rim. Loosen the eye bolt holding the brake cable with a 10mm spanner allowing the cable to slip down through the hole and re-tighten. The brake pads should be parallel to and be set 1.5mm to 2mm away from the rim. To set, apply the brakes firmly and check pad clearance, then loosen the cable eye bolt again. Squeeze the brake arms together until the pads just touch the rim, and re-tighten the eye bolt. Refer P. 46-47 for more detail.



Do not ride the bicycle until the brakes are functioning properly. Test the brakes by squeezing the brake control lever firmly and trying to push the bicycle forward.

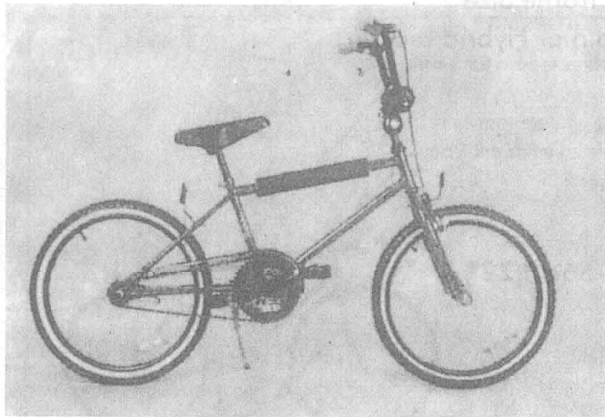

8 . Finally

For BMX bicycles attach the safety crash pads as shown. Check tyre pressure is inflated to the range recommendation on the tyre sidewalls. Attach the orange reflectors to the spokes of both wheels directly opposite the valve stem and within 75mm of the rim. Attach the white reflector to the front reflector bracket and the red reflector to the rear reflector bracket using an 8mm spanner or Phillips head screwdriver. Before riding ensure all nuts, bolts and fittings on the bicycle have been correctly tightened.

Correct maintenance of your bicycle will ensure many years of happy riding. Service your bicycle regularly yourself by referring to the relevant sections of this manual OR take it to your specialist bicycle shop.





CORRECT FRAME SIZE

When selecting a new bicycle the correct choice of frame size is a very important safety consideration. Most full sized gents bicycles come in a range of frame sizes. These sizes usually refer to the distance between the centre of the bottom bracket and the top of the frame seat tube.



For safe and comfortable riding there should be a clearance of between 25mm and 50mm between the crotch of the intended rider and the top frame tube of the bicycle, while rider straddles the bicycle with both feet flat on the ground.

The ideal clearance will vary between types of bicycles and rider preference. This makes straddling the frame when off the saddle easier and safer in situations such as sudden traffic stops.

The correct sized female style bicycle can be checked using a male model as a guide.

The following chart and diagram will help you make the correct choice.

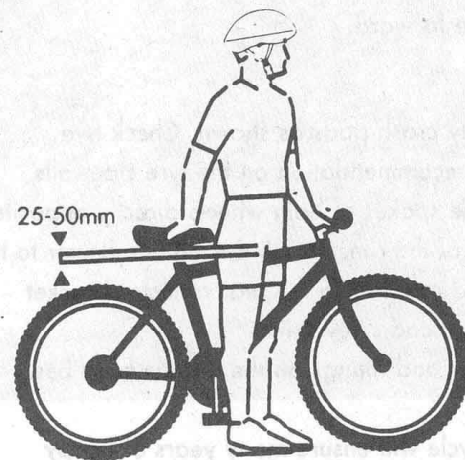

Frame Sizing Guide

Approx. rider leg length	Suggested frame Size for Mountain or Hybrid bicycle
61-69cm	37cm(15")
66-76cm	43cm(18")
71-79cm	45cm(18")
76-84cm	50cm(18")
79-86cm	52cm(21")
81-89cm	53cm(21")-56cm(22")
86-94cm	

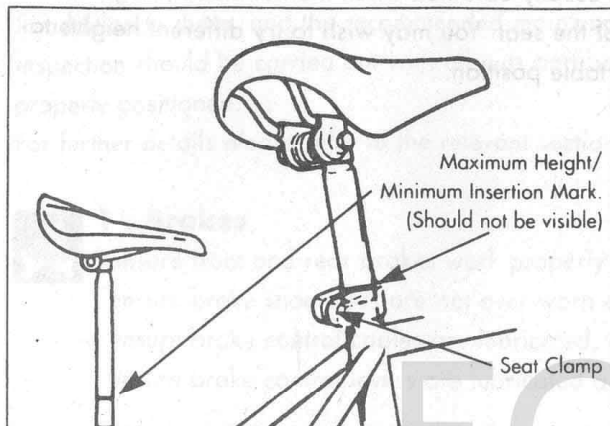

RIDING POSITION

1 . Saddle Height

In order to obtain the most comfortable riding position, offering the best possible pedalling efficiency, the seat height should be set correctly in relation to the riders leg length. The correct saddle height should not allow leg strain from over-extension, and the hips should not rock from side to side while pedalling.

While sitting on the bicycle with one pedal at its lowest point, place the ball of your foot on that pedal. The correct saddle height will allow that knee to be slightly bent in this position. If the rider then places the heel of that foot on the pedal the leg should be almost straight.



Ensure seat pillar does not extend beyond the minimum insertion mark. (Refer P. 37 on how to adjust seat height.)

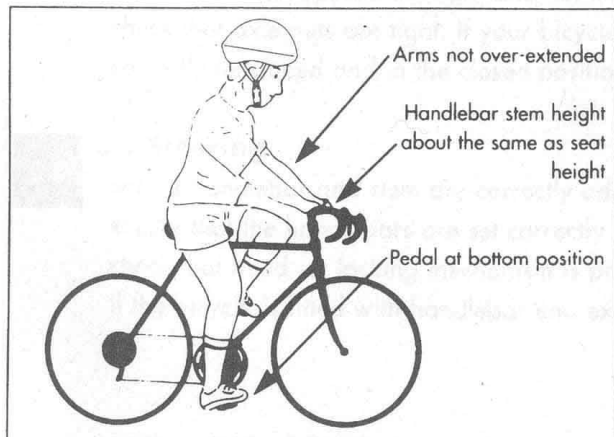

2 . Reach

To obtain maximum comfort the rider should not overextend his or her reach when riding. While placing your elbow against the seat and stretching out your arm, the distance between the outstretched fingertips and the handlebar should be 2cm-5cm.

To adjust this distance, the position of the seat can be altered in relation to the seat pillar. (Refer to Part 5 on how to adjust the seat clamp).

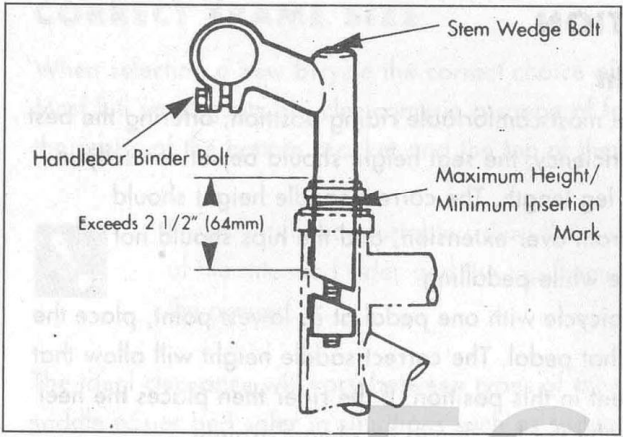

3 . Handlebar Height

Maximum comfort is usually obtained when the handlebar height is equal to the height of the seat. You may wish to try different heights to find the most comfortable position.

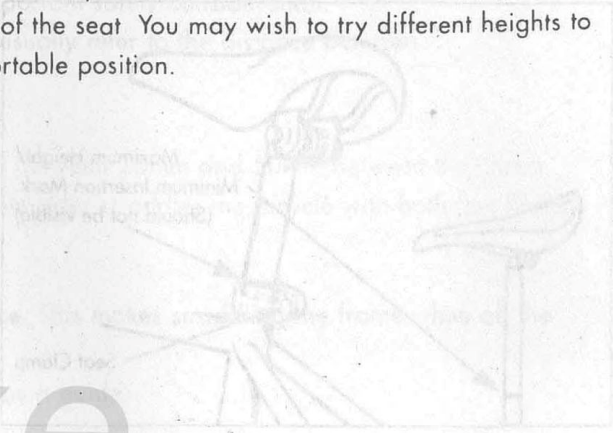

Ensure handlebar stem does not extend beyond the minimum insertion mark. (Refer to Part 5 on how to adjust Handlebars).

SAFETY CHECKLIST

Before every ride it is important to carry out the following safety checks.

In addition to these, and the recommended maintenance in Parts 4 and 5 of this manual, every fortnight a thorough inspection should be carried out with all nuts and bolts tightened, worn and damaged parts replaced, and components properly positioned.

For further details please refer to the relevant sections in parts 4 and 5.



1 . Brakes

- . ensure front and rear brakes work properly
- . ensure brake shoe pads are not over worn and are correctly positioned in relation to the rims
- . ensure brake control cables are lubricated, correctly adjusted, and display no obvious wear
- . ensure brake control levers are lubricated and tightly secured to the handlebar



2 . Wheels and Tyres

- . ensure tyres are inflated to within the maximum recommended limit as displayed on the tyre sidewall
- . ensure tyres have tread and have no bulges or excessive wear
- . ensure rims run true and have no obvious buckles or kinks
- . ensure all wheel spokes are tight and not broken
- . check that axle nuts are tight. If your bicycle is fitted with quick release axles, make sure locking levers are correctly tensioned and in the closed position



3 . Steering

- . ensure handlebar and stem are correctly adjusted and tightened and allow proper steering
- . ensure that the handlebars are set correctly in relation to the forks and the direction of travel
- . check that head set locking mechanism is properly adjusted and tightened
- . if the bicycle is fitted with handlebar end extensions, ensure they are properly positioned and tightened





4 . Chain

- . ensure chain is oiled, clean and runs smoothly
- . extra care is required in wet or dusty conditions



5 . Bearings

- . ensure all bearings are lubricated, run freely and display no excess movement, grinding or rattling
- . check Headset, Wheel Bearings, Pedal Bearings and Bottom Bracket Bearings



6 . Cranks and Pedals

- . ensure pedals are securely tightened to the cranks
- . ensure cranks are securely tightened to the axle and are not bent



7 . Derailleurs

- . check that front and rear mechanisms are adjusted and function properly
- . ensure control levers are securely attached
- . ensure derailleurs, shift levers and control cables are properly lubricated



8 . Frame and Fork

- . check that the frame and fork are not bent or broken
- . if either are bent or broken they should be replaced



9 . Accessories

- . ensure that all reflectors are properly fitted and not obscured
- . if night riding, ensure dynamo or battery powered lights are fitted to the front and rear of the bicycle and are functioning properly
- . ensure all other fittings on the bike are properly and securely fastened and functioning
- . ensure the rider and a child seated in a safety seat are both wearing helmets

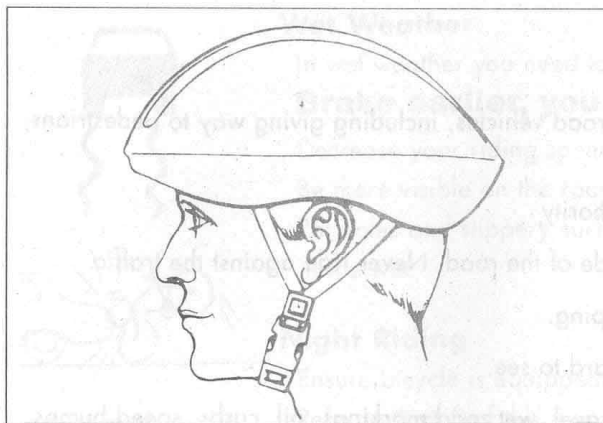

HELMETS

It is strongly advised that a properly fitting, approved, bicycle safety helmet be worn at all times when riding your bicycle. In addition, if you are carrying a passenger in a child safety seat, they must also be wearing a helmet.

A bicycle helmet must fit correctly

The right helmet should:

- be comfortable
- be lightweight
- have good ventilation.

EGBike

EGBike

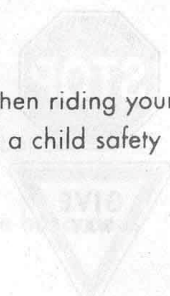

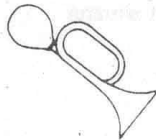
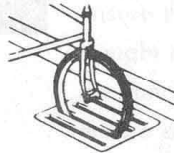

RIDING SAFELY

General Rules

- When riding obey the same road laws as all other road vehicles, including giving way to pedestrians, and stopping at red lights and stop signs.
- For further information contact the Road Traffic Authority.
- Ride predictably and in a straight line on the left side of the road. Never ride against the traffic.
- Use correct hand signals to indicate turning or stopping.
- Ride defensively. To other road users you may be hard to see.
- Concentrate on the path ahead. Avoid pot holes, gravel, wet road markings, oil, curbs, speed bumps, drain grates and other obstacles.
- Cross tram and train tracks at a 90 degree angle or walk your bicycle across.
- Expect the unexpected such as opening car doors or cars backing out of concealed driveways.
- Be extra careful at intersections and when preparing to pass other vehicles.
- Familiarise yourself with all the bicycle's features. Practice gear shifts, braking.
- If you are wearing loose trousers, use leg clips or elastic bands to prevent them being caught in the chain.
- Don't carry packages or passengers that will interfere with your visibility or control of the bicycle.
- Don't use items that may restrict your hearing.
- When braking, always apply the rear brake first, then the front. The front brake is more powerful and if it is not correctly applied you may lose control and fall.
- Maintain a comfortable stopping distance from all other riders, vehicles and objects. Safe braking distances and forces are subject to the prevailing weather conditions.

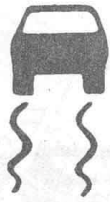

Wet Weather

In wet weather you need to take extra care.

Brake earlier, you will take a longer distance to stop

- Decrease your riding speed, avoid sudden braking and take corners with additional caution.
- Be more visible on the road - wear reflective clothing and use safety lights.
- Pot holes and slippery surfaces such as line markings and tram tracks all become more hazardous in the wet.

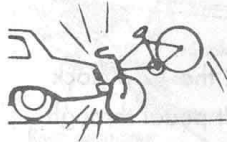

Night Riding

- Ensure bicycle is equipped with a full set of correctly positioned and clean reflectors
- Refer to Part 5 of this manual.

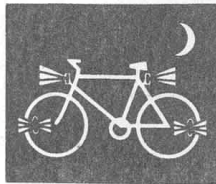

Never venture on roads at night without functioning front and rear bicycle lights.

EGBike

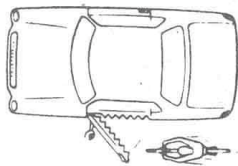

- Use a properly functioning lighting set comprising a white front lamp and a red rear lamp.
- If using battery powered lights make sure batteries are well charged. If using dynamo powered lights ensure wiring is properly connected and not loosely fitted.
- Some rear lights available have a flashing mechanism which enhances visibility.
- Wear reflective and light coloured clothing.
- Ride at night only if necessary. Slow down and use familiar roads with street lighting if possible.



Pedalling Technique

- Position the ball of your foot on the centre of the pedal.
- When pedalling, ensure your knees are parallel to the bicycle frame.
- To absorb shock, keep your elbows slightly bent.
- Learn to operate the gears properly



Hill Technique

- . gear down before a climb and continue gearing down as required to maintain pedalling speed
- . if you reach the lowest gear and are struggling, stand up on your pedals. You will then obtain more power from each pedal revolution
- . on the descent, use the high gears to avoid rapid pedalling
- . do not exceed a comfortable speed, maintain control and take additional care

Cornering Technique

Brake slightly before cornering and prepare to lean your body into the corner. Maintain the inside pedal at the 12 o'clock position and slightly point the inside knee in the direction you are turning. Keep the other leg straight, don't pedal through fast or tight corners.

Rules for Children

To avoid accidents, teach children good riding skills with an emphasis on safety from an early age.

- 1 . Always wear a properly fitting helmet
- 2 . Do not play on driveways or the road
- 3 . Do not ride on busy streets
- 4 . Do not ride at night
- 5 . Obey all the traffic laws, especially stop signs and red lights
- 6 . Be aware of other road vehicles behind and nearby
- 7 . Before entering a street: Stop. Look right, left, and right again for traffic
If there's no traffic, proceed into the roadway
- 8 . If riding downhill be extra careful. Slow down using the brakes and maintain control of the steering



Never take your hands off the handlebars, or your feet off the pedals when riding downhill.

Children should be made aware of all possible riding hazards and correct riding behaviour before they take to the streets
- **don't leave it up to trial and error.**

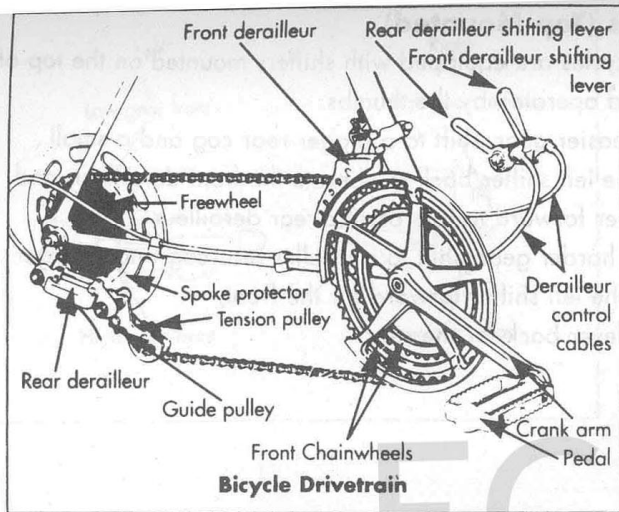

Bicycle Drivetrain

GEARS . HOW TO OPERATE

Derailleur Gears

Most multispeed bicycles today are equipped with what are known as derailleur gears.

They operate using a system of levers and mechanisms to move the drive chain between different sized driving gears or cogs.

The purpose of gears is to let you maintain a constant, steady pedalling pace under varying conditions. This means your riding will be less tiring without unnecessary straining up hills or fast pedalling down hill.

Bicycles come with a variety of gear configurations from 5 through to 24 speed. A 5-6 speed bicycle will have a single front chainwheel, a rear derailleur only and 5 or 6 cogs on the rear hub. Bicycles with more gears will also have a front derailleur, a front chainwheel with 2-3 cogs and up to 8 cogs on the rear hub.

Operating Principles

No matter how many gears, the operating principles are the same.

The front derailleur is operated by the left shift lever and the rear derailleur by the right. To operate you must be pedalling forward.

You can not shift derailleur gears when you are stopped or when pedalling backwards. Before shifting ease up on your pedalling pressure.

On approaching a hill, shift to a lower gear before your pedalling speed slows down too much for a smooth shift. When coming to a stop, shift to a lower gear first so it will be easier when you start riding again.

If, after selecting a new gear position, you hear a slight rubbing noise from the front or rear gears, gently adjust the appropriate shifter until the noise goes away.

To avoid rapid chain wear it is recommended that you avoid using the extreme combinations of gear positions shown in the diagrams.

EGBike



Top Gear (Harder)

Small rear sprocket
Large chainwheel

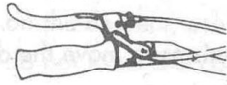

Left hand lever forward



Right hand lever back

Bottom Gear (Easier)

Large rear sprocket
Small chainwheel



Left hand lever back



Right hand lever forward

Thumb Shifters (Top Mounted)

Most MTB style bicycles are equipped with shifters mounted on the top of the handlebars and operated by the thumbs.

To select a lower, easier gear, shift to a bigger rear cog and a small chainwheel. Pull the left shifter back to operate the front derailleur, and push the right shifter forward to operate the rear derailleur.

To select a higher, harder gear, shift to a smaller rear cog and a larger chainwheel. Push the left shifter forward for the front, and pull the right lever back for the rear.

EGBike

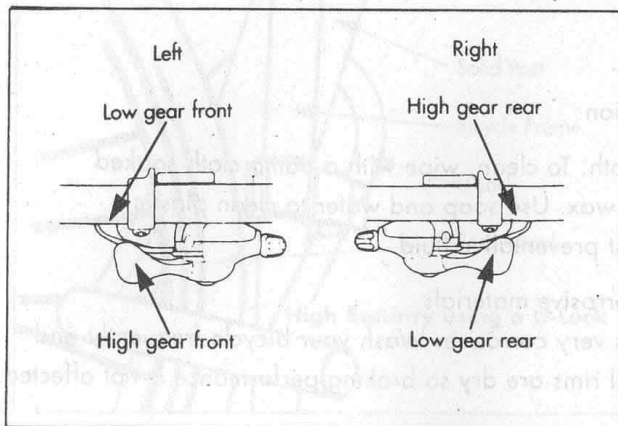

Below the Bar Shifters

Many of today's more upmarket Mountain style bicycles now use a shift lever arrangement mounted on the underside of the handlebars, which uses two levers operated by the thumb and index finger.

To select a lower gear push the larger (lower) right shifter with your thumb to engage a larger rear cog. One firm push shifts the chain one cog, continuing to push will move the chain over multiple cogs. Pushing the smaller (upper) left shifter with your index finger moves the chain from a larger to a smaller chainwheel.

To select a higher gear push the smaller (upper) right lever with your index finger to engage a smaller rear cog. Pushing the larger (lower) left lever with your thumb will move the chain from a smaller to a larger chainwheel.

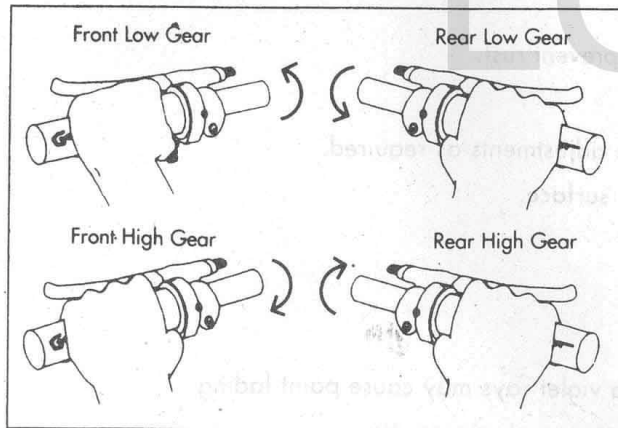

Hand Grip Shifters

Some bicycles are now being equipped with a shifting mechanism, called Grip Shift, which is built into the handlebar grips and does not make use of separate levers.

The actuating mechanism is built into the inside part of the grip that the web of the thumb and index finger closes around.

To select a lower gear, twist the right shifter toward you to engage a larger rear cog.

You can shift one gear at a time by moving the Grip Shift one click, or through multiple gears by continued twisting. By twisting the left shifter forward or away from you a smaller chainwheel can be selected.

To select a higher gear, twist the right shifter forward or away from you to engage a smaller rear cog. To engage a larger front chainwheel, twist the left shifter towards you.

Single shifts can be achieved by twisting one click at a time and multiple shifts by larger twists.





BICYCLE CARE

Basic Maintenance

The following procedures will ensure your bicycle is maintained in top condition.

For painted frames, dust the surface and remove any loose dirt with a dry cloth. To clean, wipe with a damp cloth soaked in a mild detergent mixture. Dry with a cloth and polish with car or furniture wax. Use soap and water to clean plastic parts and rubber tyres. Chrome plated bikes should be wiped over with a rust preventative fluid.

Store your bicycle under shelter. Avoid leaving it in the rain or exposed to corrosive materials.

Riding on the beach or in coastal areas exposes your bicycle to salt, which is very corrosive. Wash your bicycle frequently and wipe or spray all unpainted parts with an anti-rust treatment. Make sure wheel rims are dry so braking performance is not affected. After rain, dry your bicycle and apply anti-rust treatment.

If the hub and bottom bracket bearings of your bicycle have been submerged in water, they should be taken out and re-greased. This will prevent accelerated bearing deterioration.

If paint has become scratched or chipped to the metal, use touch up paint to prevent rust. Clear nail varnish can also be used as a preventative measure.

Regularly clean and lubricate all moving parts, tighten components and make adjustments as required.

The use of alloy components minimises the number of places where rust can surface.

Storage

Keep your bicycle in a dry location away from the weather and the sun. Ultra violet rays may cause paint fading or cracking to rubber and plastic parts.

Before storing your bicycle for a long period of time, clean and lubricate it and wax the frame. Deflate the tyres to half pressure and hang the bicycle off the ground. Don't store near electric motors as ozone emissions may effect the rubber and paint.

Don't cover with plastic as "sweating" will result, which may cause rusting.

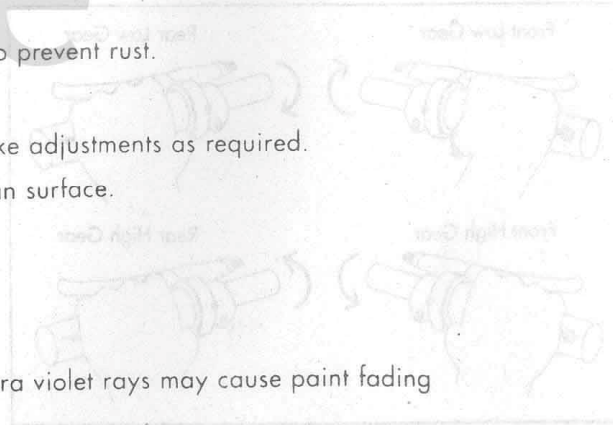
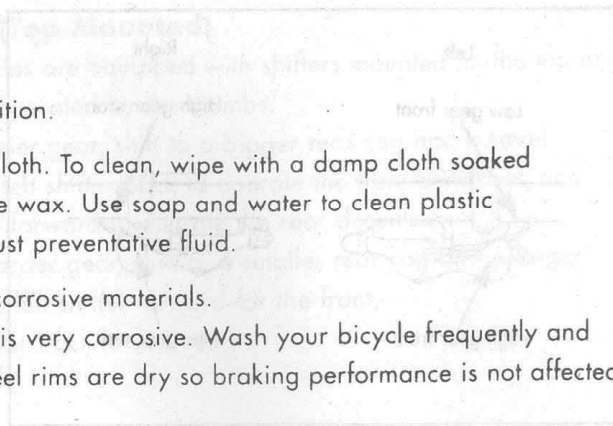

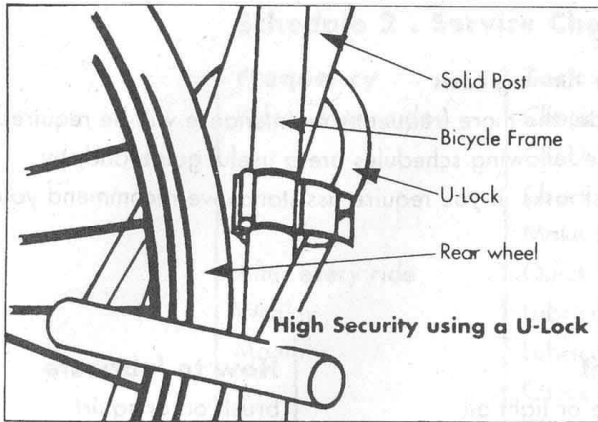

Security

It is advisable that the following steps be taken to prepare for and help prevent possible theft.

- 1 . Maintain a record of the bicycle serial number, generally located on the frame underneath the bottom bracket.
- 2 . Register the bicycle with the manufacturer/distributor and local police.
- 3 . Invest in a high quality bicycle lock that will resist hack saws and bolt cutters. Always lock your bicycle to an immovable object, such as a lamp post, if it is left unattended.

EGBike



BICYCLE MAINTENANCE



Correct routine maintenance of your new bike will ensure:

Smooth running . Longer lasting components . Safer riding . Lower running costs
Every time you ride your bicycle it's condition changes. The more you ride, the more frequently maintenance will be required. We recommend you spend a little time on regular maintenance tasks. The following schedules are a useful guide and, by referring to Part 5 of this manual, you should be able to accomplish most tasks. If you require assistance we recommend you see your specialist bicycle dealer.

Schedule 1 . Lubrication

Frequency	Component	Lubricant	How to lubricate	
Weekly	chain	chain lube or light oil	brush on or squirt	
	derailleur wheels	chain lube or light oil	brush on or squirt	
	derailleurs	oil	oil can	
	brake calipers	oil	3 drops from oil can	
	brake levers	oil	2 drops from oil can	
Monthly	shift levers	lithium based grease	disassemble	
	brake cable ends	oil	1 drop from oil can	
	hubs	lithium based grease	disassemble	
6 Monthly	bottom bracket	lithium based grease	disassemble	
	pedals	lithium based grease	disassemble	
	freewheel	oil	2 squirts from oil can	
	brake cables	lithium based grease	disassemble	
	derailleur cables	lithium based grease	disassemble	
	Yearly	wheel bearings	lithium based grease	disassemble
		headset	lithium based grease	disassemble
seat pillar		lithium based grease	disassemble	

Note: The frequency of maintenance should increase with lots of usage and use in wet or dusty conditions. Do not over lubricate - remove excess lubricant to prevent dirt build up.

Schedule 2 . Service Checklist

Frequency	Task
Before every ride	Check tyre pressure
	Check brake operation
	Check wheels for loose spokes
	Make sure nothing is loose
After every ride	Quick wipe down with damp cloth
Weekly	Lubrication as per schedule 1
Monthly	Lubrication as per schedule 1
	Check derailleur adjustment
	Check brake adjustment
	Check brake and gear cable adjustment
	Check tyre wear and pressure
	Check wheels are true and spokes tight
	Check hub, head set and crank bearings for looseness
	Check pedals are tight
	Check handlebars are tight
	Check seat and seat post are tight and comfortably adjusted
	Check frame and fork for trueness
	Check all nuts and bolts are tight
	Lubrication as per schedule 1
6 Monthly	Check all points as per Monthly service
	Check and replace brake pads if required
	Check chain for excess play or wear
Yearly	Lubrication as per schedule 1

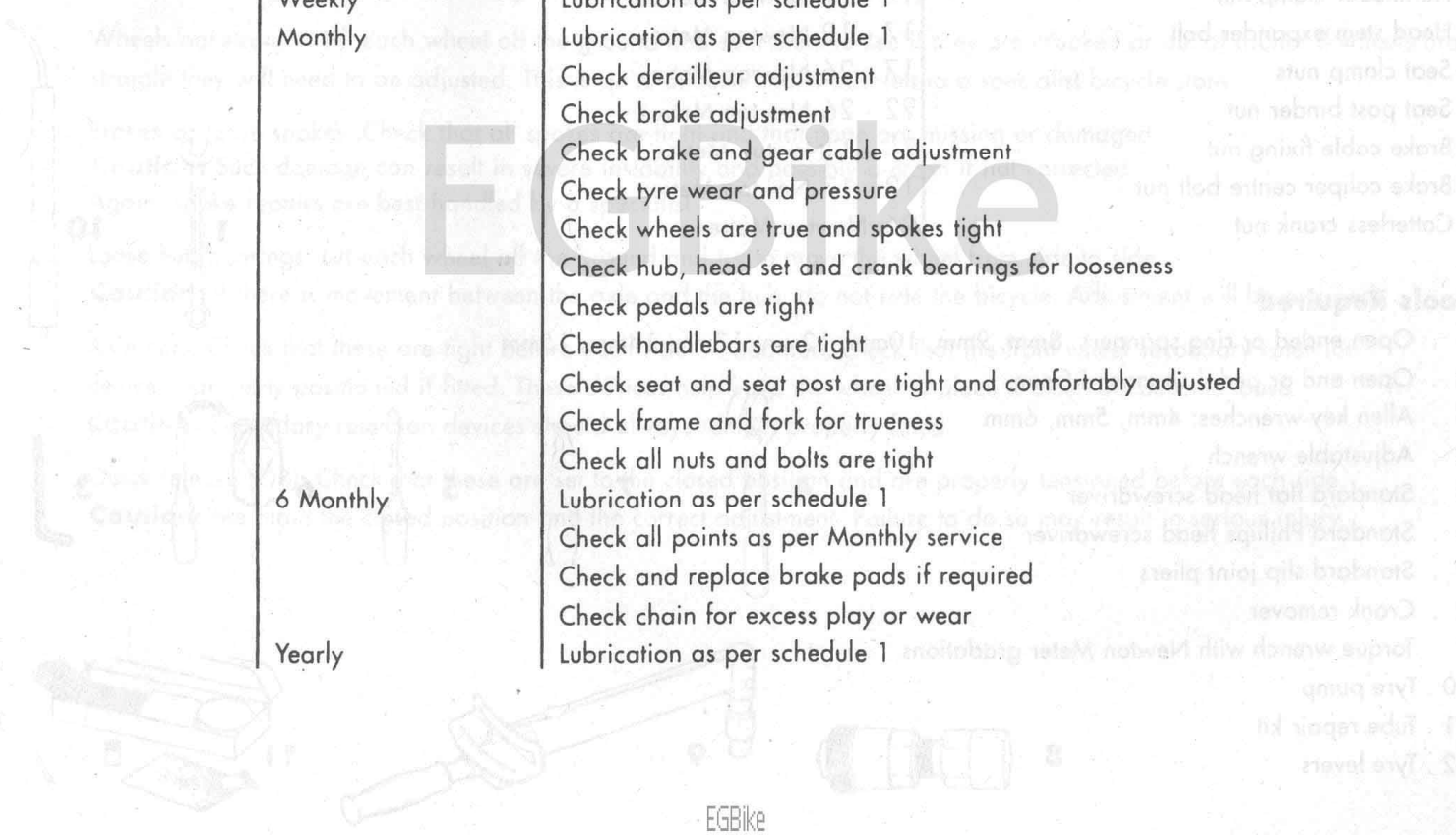

EGBike



Torque Requirements

When performing routine adjustments on nuts and bolts it is recommended that a torque wrench be used to prevent overtightening and damage to the threads. The following are key components that should be tightened using a torque wrench.

Component	Torque
Front axle nuts	22 - 26 Newton Metres
Rear axle nuts	22 - 26 Newton Metres
Handlebar clamp nut	17 - 19 Newton Metres
Head stem expander bolt	17 - 19 Newton Metres
Seat clamp nuts	17 - 26 Newton Metres
Seat post binder nut	22 - 26 Newton Metres
Brake cable fixing nut	7 - 11 Newton Metres
Brake caliper centre bolt nut	12 - 17 Newton Metres
Cotterless crank nut	26 Newton Metres

Tools Required

- 1 . Open ended or ring spanners: 8mm, 9mm, 10mm, 12mm, 13mm, 14mm, 15mm
- 2 . Open end or pedal spanner 15mm
- 3 . Allen key wrenches: 4mm, 5mm, 6mm
- 4 . Adjustable wrench
- 5 . Standard flat head screwdriver
- 6 . Standard Phillips head screwdriver
- 7 . Standard slip joint pliers
- 8 . Crank remover
- 9 . Torque wrench with Newton Meter gradations
- 10 . Tyre pump
- 11 . Tube repair kit
- 12 . Tyre levers

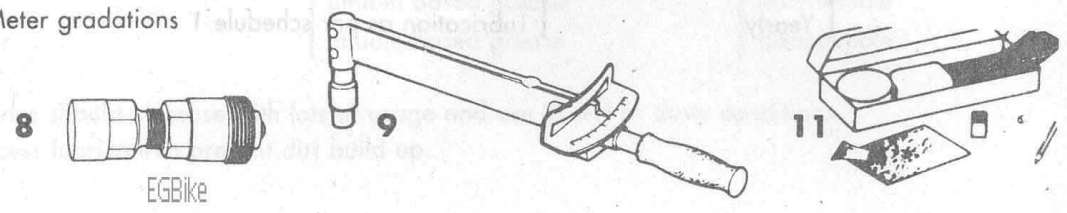
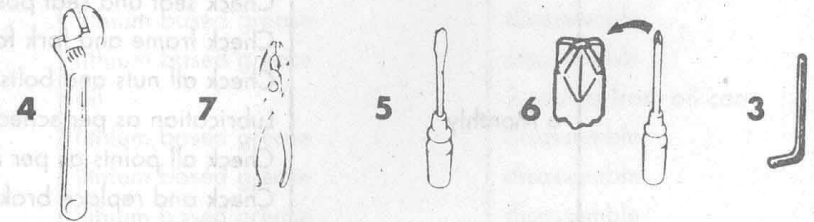
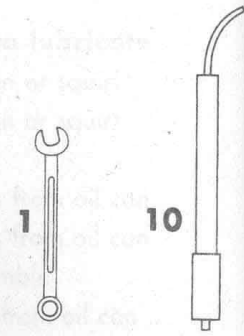

WHEELS AND TYRES

Wheel Inspection

It is most important that wheels are kept in top condition. Properly maintaining your bicycle's wheels will help braking performance and stability when riding. Be aware of the following potential problems:

Dirty or greasy rims: **Caution:** These can render your brakes ineffective. Do not clean them with oily or greasy materials.

When cleaning, use a clean rag or wash with soapy water, rinse and air dry. Don't ride while they're wet.

When lubricating your bicycle, don't get oil on the rim braking surfaces.

Wheels not straight: Lift each wheel off the ground and spin them to see if they are crooked or out of round. If wheels are not straight they will need to be adjusted. This is quite difficult and is best left to a specialist bicycle store.

Broken or loose spokes: Check that all spokes are tight and that none are missing or damaged.

Caution: Such damage can result in severe instability and possibly a crash if not corrected.

Again, spoke repairs are best handled by a specialist.

Loose hub bearings: Lift each wheel off the ground and try to move the wheel from side to side.

Caution: If there is movement between the axle and the hub, do not ride the bicycle. Adjustment will be required.

Axle nuts: Check that these are tight before each ride. In addition, check that the front wheel secondary retention device is properly positioned if fitted. These devices help keep the wheel in place if axle nuts become loose.

Caution: Secondary retention devices should always remain properly fitted.

Quick release (QR): Check that these are set to the closed position and are properly tensioned before each ride.

Caution: Maintain the closed position and the correct adjustment. Failure to do so may result in serious injury.





Tyre Inspection

Tyres must be maintained properly to ensure road holding and stability. Check the following areas:

. Inflation: Ensure tyres are inflated to the pressure indicated on the tyre sidewalls. It is better to use a tyre gauge and a hand pump than a service station pump.

Caution: If inflating tyres with a service station pump, take care that sudden over inflation does not cause a blow out.

. Bead seating: When inflating or refitting tyres make sure that the bead is properly seated in the rim.

. Tread: Check that the tread shows no signs of excessive wear or flat spots, and that there are no cuts or other damage.

Caution: Excessively worn or damaged tyres should be replaced.

. Valves: Make sure valve caps are fitted and that valves are free from dirt. A slow leak caused by the entry of dirt can lead to a flat tyre, and possibly a dangerous situation.



Recommended tyre pressures:

The recommended pressure moulded on the sidewall of your bicycles' tyres should match the following chart. Use this as a guide.

BMX	241-344 k.p.a.	(35-50 p.s.i.)
MTB	276-448 k.p.a.	(40-65 p.s.i.)

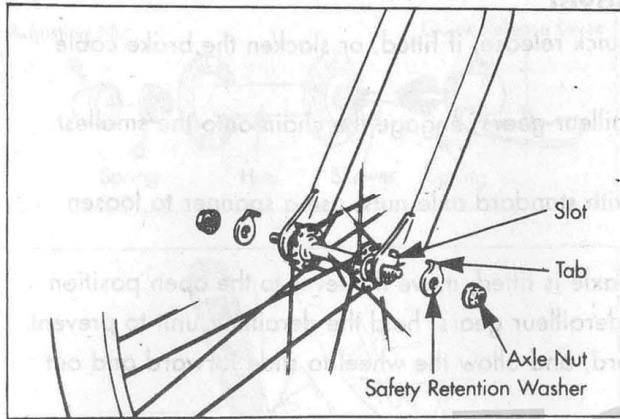

Front Wheel Removal

- 1 . Open the brake quick release, if fitted, or slacken the brake cable adjuster.
- 2 . If wheel is fitted with standard axle nuts, use a spanner to loosen them off. If secondary retention devices are fitted you will need to loosen the nuts sufficiently to allow clearance to remove the wheel.
- 3 . If a quick release axle is fitted, move the lever to the open position. If secondary retention devices are fitted, loosen the adjusting nut at the opposite end to the QR lever enough to allow the wheel to be removed.
- 4 . Remove the wheel.

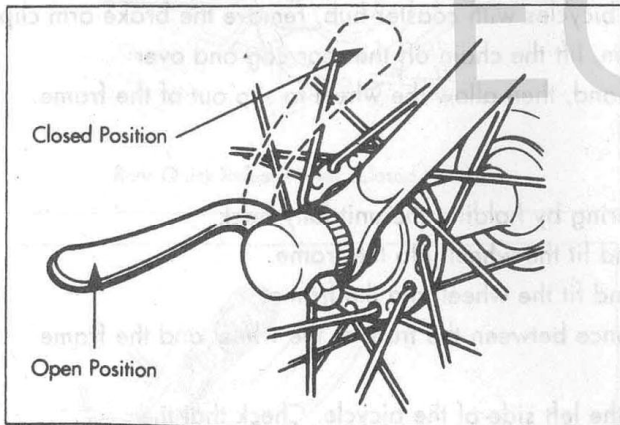

Front Wheel Replacement

- 1 . Replacement follows almost the reverse sequence to removal.
- 2 . Place the wheel into the frame ensuring that the axle fits well up against the fork end slots. You may need to slightly prise apart the fork legs.
- 3 . If the wheel has a QR axle, ensure the quick release lever is open and on the left side of the bicycle. Check that the QR tension is correct and close the lever so that it is parallel to the fork. This position will prevent accidental opening when riding.
- 4 . If secondary retention devices are fitted, make sure they are correctly located in the fork ends.
- 5 . Tighten both axle nuts firmly, if fitted.
- 6 . Re-set the brake quick-release or re-tension the brake cable adjuster.



Failure to properly refit a front wheel may result in a serious accident.



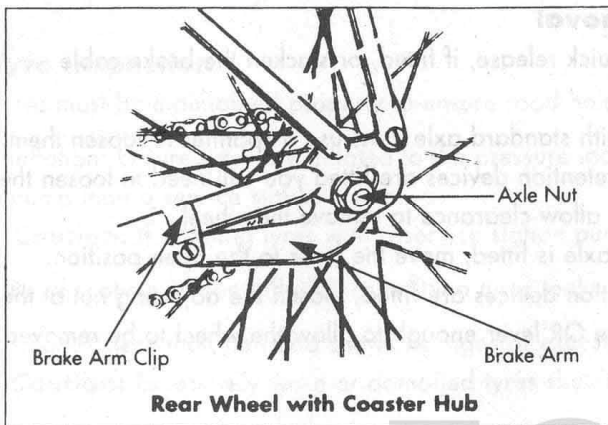

Rear Wheel Removal

- 1 . Open the brake quick release, if fitted, or slacken the brake cable adjuster.
- 2 . If bicycle has derailleur gears, engage the chain onto the smallest rear cog.
- 3 . If wheel is fitted with standard axle nuts, use a spanner to loosen them off.
- 4 . If a quick release axle is fitted, move the lever to the open position.
- 5 . If the bicycle has derailleur gears, hold the derailleur unit to prevent it springing forward, and allow the wheel to slide forward and out of the frame.
- 6 . Rest the bike upside down on the handlebars and saddle.
- 7 . For single geared bicycles with coaster hub, remove the brake arm clip from the brake arm, lift the chain off the rear cog and over the rear axle by hand, then allow the wheel to slip out of the frame.

Rear Wheel Replacement

- 1 . Replacement follows almost the reverse sequence to removal.
- 2 . For derailleur geared bicycles, take up the tension in the rear derailleur spring by holding the unit fully back. Feed the top part of the smallest hub cog into the top part of the chain, and fit the wheel into the frame.
- 3 . For single geared bicycles, lift the chain over the axle and onto the cog, and fit the wheel into the frame.
- 4 . Make sure the wheel is properly centred in the frame by checking the distance between the front of the wheel and the frame chainstay tubes on either side. Firmly tighten both axle nuts.
- 5 . If the wheel has a QR axle, ensure the quick release lever is open and on the left side of the bicycle. Check that the QR tension is correct and close the lever so that it is parallel to the frame seat stay tube. This position is best to prevent accidental opening while riding.
- 6 . On coaster hub bicycles, reinstall the brake arm to the brake arm clip on the chainstay.
- 7 . Reset the brake quick-release or re-tension the brake cable adjuster.

27



Failure to properly refit a rear wheel may result in a serious accident.

EGBike

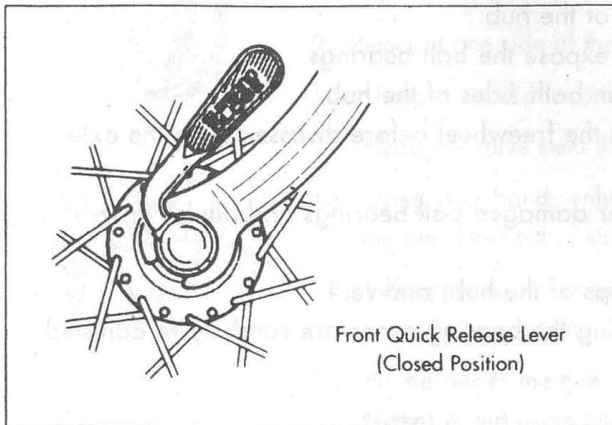
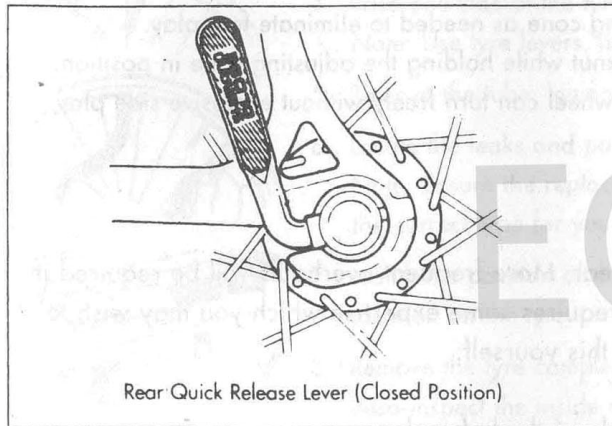
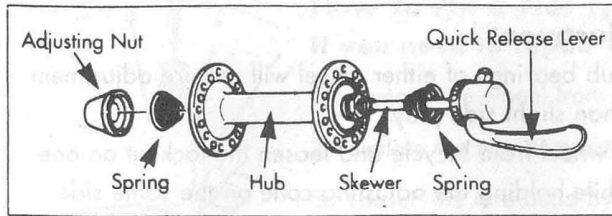

Correct QR Axle Setting

Some bicycles have wheel axles that incorporate a Quick Release (QR) mechanism. This allows easy wheel removal without the need for tools. The mechanism uses a long bolt with an adjusting nut on one end, and a lever operating a cam-action tensioner on the other.



Correct adjustment of the QR is vitally important to avoid an accident caused by loose wheels.

1. To set, turn the lever to the open position so that the curved part faces away from the bicycle.
2. While holding the lever in one hand, tighten the adjusting nut until it stops.
3. Pivot the lever towards the closed position. When the lever is halfway closed, there must be firm resistance to turning it beyond that point. If resistance is not firm, then further tighten the adjusting nut in a clockwise direction.
4. Continue to pivot the lever all the way to the closed position so that the curved part of the lever faces the bicycle.
5. The wheel is tightly secured when the serrated surfaces of the QR clamping parts actually begin to cut into the bicycle frame/fork surfaces.
6. Note that the same procedure applies when operating a QR seat post binder mechanism.



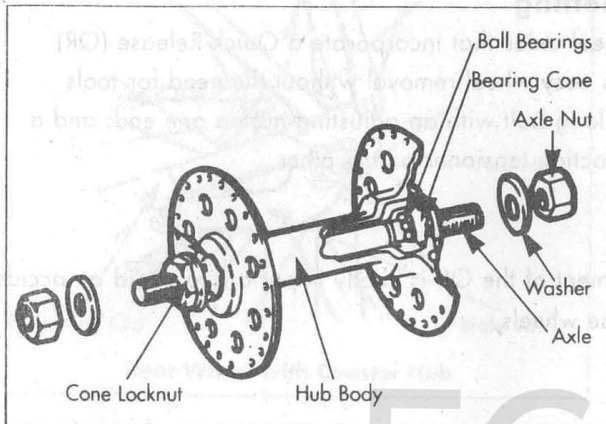

Hub Lubrication

Wheel bearings should be disassembled and re-greased at least once a year. More frequent overhauls will be required if the bicycle has been used in very wet or muddy conditions. Disassembly requires some expertise which you may wish to refer to a specialist, but the following will help you if you wish to attempt this yourself:

1. Remove the wheel from the frame.
2. Remove the axle nut, cone lock nut, and the bearing cone from one side of the hub axle.
3. Remove the axle, complete with cone and locknut, from the other side of the hub.
4. Carefully remove the dust caps, if fitted, from both sides of the hub to expose the ball bearings.
5. Carefully remove the loose ball bearings or ball retainers, if fitted, from both sides of the hub.
6. On rear hubs with screw on type freewheels, you may need to remove the freewheel before disassembling the axle. This requires a special tool.
7. Thoroughly clean, and inspect for damage, all the hub parts. Check for damaged ball bearings and pits or grazes in the bearing surfaces. Replace if necessary.
8. Pack grease into each clean or new ball retainer and into the inner cups of the hub, and refit.
9. Re-assemble the hub axle in reverse sequence to disassembling, ensuring the bearing cones are carefully re-adjusted.

Hub Bearing Adjustment

When checked, the hub bearings of either wheel will require adjustment if there is any more than slight side play.

1. To adjust, remove wheel from bicycle and loosen the locknut on one side of the hub while holding the adjusting cone on the same side with a flat open end spanner.
2. Rotate the adjusting cone as needed to eliminate free play.
3. Re-tighten the locknut while holding the adjusting cone in position.
4. Re-check that the wheel can turn freely without excessive side play.

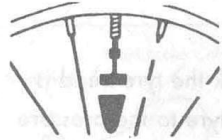

How To Fix a Flat Tyre

If you need to repair a tyre follow these steps:

1. Remove the wheel from the bicycle.
2. Deflate the tyre completely via the valve.
3. Loosen the tyre bead by pushing it inwards all the way round the rim.
4. Prise one side of the tyre bead up over the edge of the rim.
Note: Use tyre levers, not a screwdriver, otherwise you may damage the rim.
5. Remove the tube, leaving the tyre on the rim.
6. Locate the leaks and patch using a tube repair kit, carefully following the instructions, or replace the tube.
Note: Ensure the replacement tube size matches the size stated on the tyre sidewall and the valve is the correct type for your bicycle.
7. Match the position of the leak in the tube with the tyre to locate the possible cause and mark the location on the tyre.
8. Remove the tyre completely and inspect for a nail, glass etc. and remove if located.
Also inspect the inside of the rim to ensure there are no projecting spokes, rust or other potential causes.
Replace the rim tape, which covers the spoke ends, if damaged.
9. Remount one side of the tyre onto the rim.
10. Using a hand pump, inflate the tube just enough to give it some shape.
11. Place the valve stem through the hole in the rim and work the tube into the tyre. Note: Do not let it twist.
12. Using your hands only, remount the other side of the tyre by pushing the edge toward the centre of the rim. Start either side of the valve and work around the rim.
13. Before the tyre is completely mounted push the valve up into the rim to make sure the tyre can sit squarely in position.
14. Fit the rest of the tyre, rolling the last, most difficult, part on using your thumbs.

Note: Avoid using tyre levers as these can easily puncture the tube or damage the tyre.

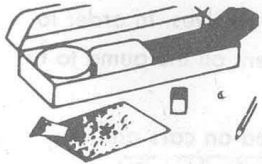
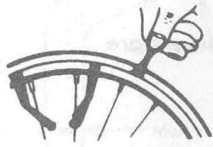

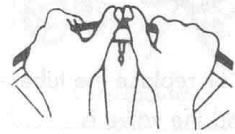
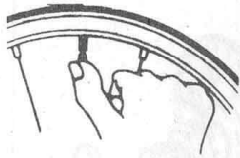
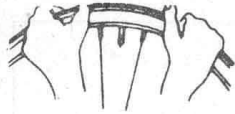

15. Check that the tube is not caught between the rim and the tyre bead at any point.

16. Using a hand pump, inflate the tube until the tyre begins to take shape, and check the tyre bead is evenly seated all the way around the rim. When properly seated, fully inflate the tyre to the pressure marked on the sidewall. Use a tyre air pressure gauge to check.

17. Replace the wheel into the frame checking that all gears, brakes and quick release levers are properly adjusted.

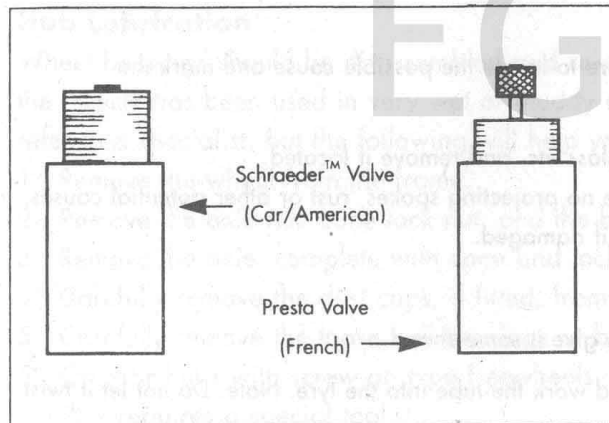

Tyre Valves

Bicycles today commonly use one of two kinds of tyre valves. In order to inflate tyres you must have the appropriate attachment on the pump to fit the bicycle valve stem.

The most commonly used type is the same that is used on cars and is known as the car valve, American valve or Schraeder™ valve. Tube inflation with these valves is easily achieved using a hand pump or service station pump by removing the valve dust cap, and then screwing on or pushing on the pump connector to the end of the valve stem. Deflation is a simple matter of depressing the pin in the end of the valve stem.

Note: Always replace the valve dust cap to prevent entry of dirt and damage to the valve.

The other commonly used valve type is the Presta valve, also known as the French or high pressure valve.

This type of valve is narrower and requires a pump with a special fitting to inflate. An adaptor screwed onto the valve stem can also be used to allow inflation via a car type pump hose. To inflate, remove the dust cap, unscrew the valve stem locknut, push down on the valve stem to free it up, then fit the pump head and inflate. To deflate, open the valve stem locknut and depress the valve stem.

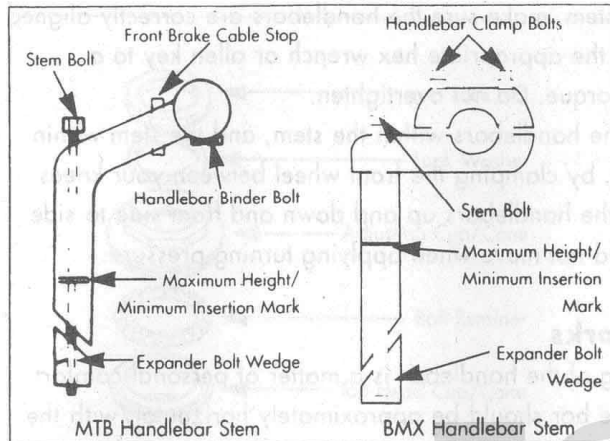

HANDLEBARS AND FORK

Handlebar Stem

The handlebar stem fits into the steering column and is held firm by the action of a binder bolt and expander wedge which, when tightened, binds with the inside of the fork steerer tube.

When removing the stem, loosen the expander bolt two or three turns, then give it a tap to loosen the wedge inside.

Lubricate by first wiping off any old grease and grime, then applying a thin film of grease to the part, including the wedge, that will be inserted into the frame.

The height of the handlebar can be adjusted to suit your comfort preference. (Refer to Part 3).

If the stem is removed from the steering column you will notice a mark about 65mm up from the bottom with the words "max. height" or "minimum insertion".

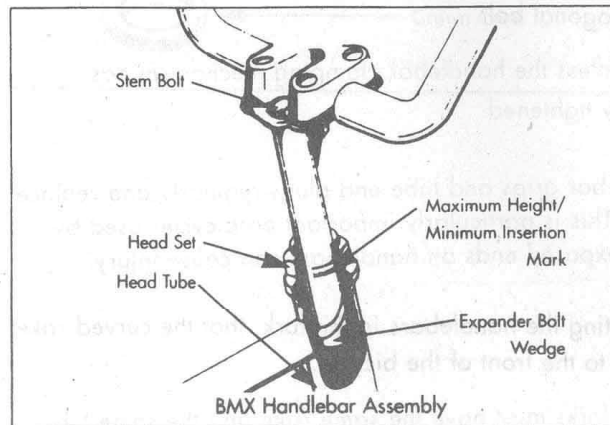

Never ride a bicycle if the stem has been raised so that the minimum insertion / max. height line can be seen.

On some MTB bicycles the front brake cable is routed through a hole in the front of the stem.



If the height is adjusted on this type of stem you will need to re-adjust the front brake.

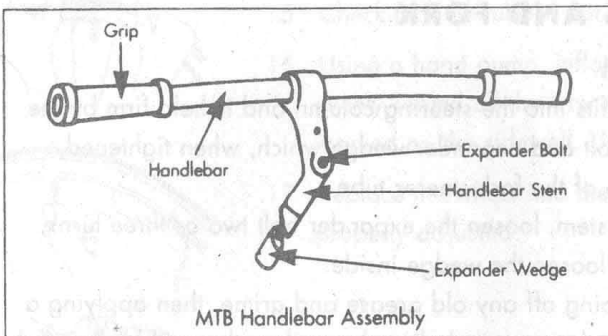

When re-fitting the stem, make sure the handlebars are correctly aligned and tightened using the appropriate hex wrench or allen key to a minimum 17Nm of torque. Do not overtighten.

Test the security of the handlebars within the stem, and the stem within the fork steerer tube, by clamping the front wheel between your knees and trying to move the handlebars up and down and from side to side. The handlebar should not move when applying turning pressure.

Handlebars / Forks

The exact positioning of the handlebar is a matter of personal comfort. For MTB bicycles, the bar should be approximately horizontal, with the ends pointing back and slightly down.

On BMX bicycles, the handlebar should remain in an approximately upright position, but can be angled back or forward slightly for comfort. BMX style bicycles may have four clamping bolts. Tighten to 18Nm.

On MTB bicycles the handlebar is usually tightened in the stem by a single allen key bolt or hexagonal bolt.

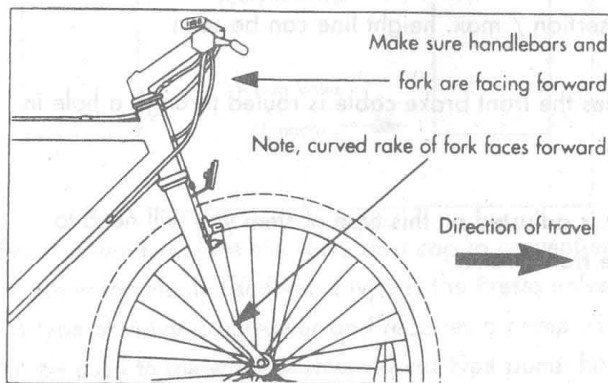

Never ride unless the handlebar clamping mechanism has been securely tightened.



Check handlebar grips and tube end plugs regularly and replace if damaged. This is particularly important on bicycles used by children, as exposed ends on handlebars can cause injury.

Make sure, when setting the handlebars in the fork, that the curved rake of the fork is angled to the front of the bicycle.



Replacement forks must have the same rake and the same tube inner diameter as those originally fitted to the bicycle.

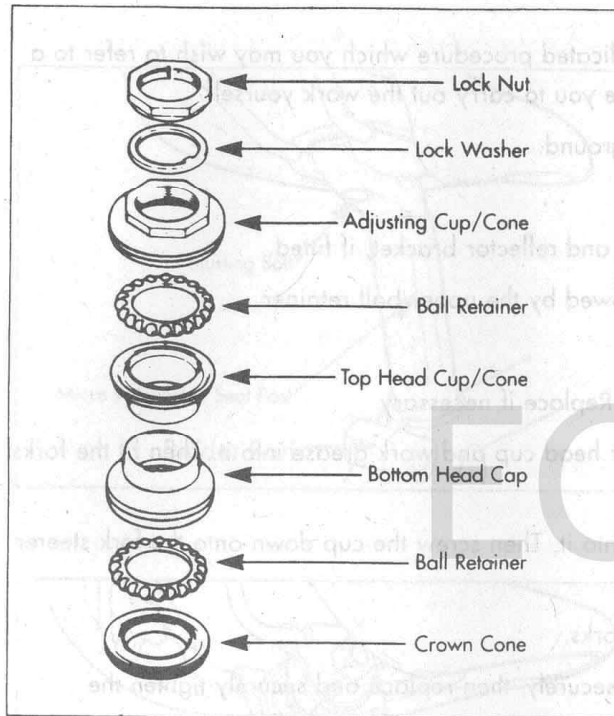

Headset

Inspection

The headset bearing adjustment should be checked every month. This is important, as it is the headset which locks the fork into the frame, and if loose can cause damage or result in an accident.

While standing over the frame top tube with both feet on the ground, apply the front brake firmly and rock the bicycle back and forward.

If you detect any looseness in the headset, it will need adjustment.

Check that the headset is not overtight by slowly rotating the fork to the right and left. If the fork tends to stick or bind at any point, the bearings are too tight.

Adjustment

Loosen the headset top locknut or remove it completely along with the reflector bracket, if fitted. Turn the adjusting cup clockwise until finger tight. Replace the lock washer or reflector bracket and re-tighten the lock nut using a suitable wrench.

Note: Do not overtighten or bearing damage will occur.



Always make sure that the headset is properly adjusted and that the headset locknut is fully tightened before riding.





Lubrication

A complete lubrication should be carried out every year. This is a complicated procedure which you may wish to refer to a specialist bicycle dealer. However the following procedure should enable you to carry out the work yourself.

- 1 . Find a way to suspend the bicycle so that the front wheel is off the ground.
- 2 . Remove the handlebar assembly from the steering tube.
- 3 . Loosen and remove the headset locknut, followed by the lockwasher and reflector bracket, if fitted.
- 4 . Support the forks with one hand and remove the adjusting cup, followed by the upper ball retainer.
- 5 . Pull the forks out of the frame and remove the lower ball retainer.
- 6 . Thoroughly clean and inspect for damage each part of the headset. Replace if necessary.
- 7 . Pack grease into both head cups. Re-fit a ball retainer into the lower head cup and work grease into it. Then fit the forks into place.
- 8 . Re-fit a ball retainer into the upper adjusting cup and pack grease into it. Then screw the cup down onto the fork steerer and into position.
- 9 . Adjust the upper cup by hand until no movement can be felt in the forks.
- 10 . Replace the lock washer, reflector bracket and lock nut, tightening securely, then replace and securely tighten the handlebar assembly.

SADDLE AND SEAT POST

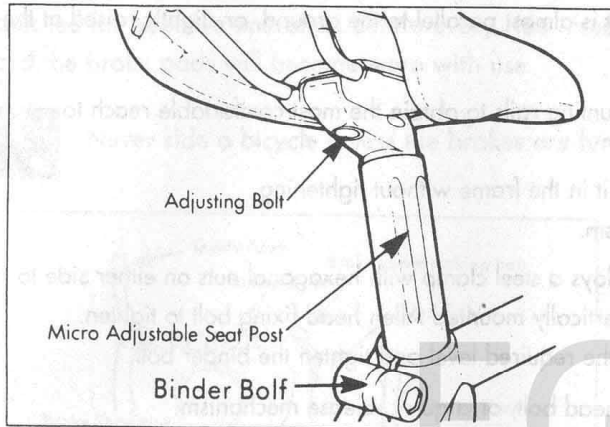

Inspection

The seat fixing bolt and the seat post binder bolt should be checked for tightness and adjustment every month. On removing the seat post from the frame, you will notice a mark about 65mm up from the bottom with the words "max. height" or "minimum insertion".



Never ride a bicycle with the seat post raised beyond the minimum insertion/max. height mark.

This may cause damage to either the seat post, the frame or possibly the rider. A minimum of 65mm of seat tube must always remain in the frame.

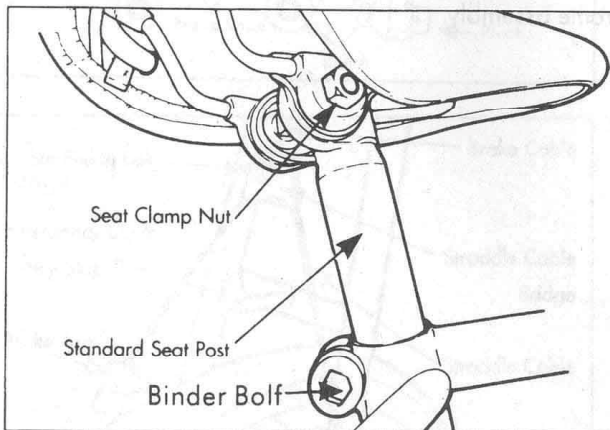

Lubrication

Remove the seat post from the frame and wipe off any old grease rust or dirt. Then apply a thin film of new grease to the part that will be inserted into the frame. Re-insert, adjust and tighten the seat post in the frame.





Adjustment

As mentioned in Part 3, the seat can be adjusted in height, angle and distance from the handlebars to suit the individual rider. Saddle angle is a matter of personal preference but when the top of the seat is almost parallel to the ground, or slightly raised at the front, the most comfortable position will usually be found.

The saddle can also be adjusted by sliding it forward or back along the mounting rails to obtain the most comfortable reach to the handlebars.

When fitting, position the seat post into the clamp under the seat and place it in the frame without tightening.

Adjust to the desired angle and position, and tighten the clamping mechanism.

There are two types of seat clamp commonly in use. The most common employs a steel clamp with hexagonal nuts on either side to tighten. The other type, known as a micro-adjustable clamp, uses a single vertically mounted Allen head fixing bolt to tighten.

After fixing the seat to the desired position on the post, adjust the height to the required level and tighten the binder bolt.

Note that the type of binder bolt may be either a hexagonal bolt, an Allen head bolt, or a quick release mechanism.

The operation of a seat post Quick Release mechanism is the same as for Quick Release hubs.

Test the security by grasping the seat and trying to turn it sideways. If it moves you will need to further tighten the binder bolt.

Note: Remember that the minimum insertion mark must remain inside the frame assembly.

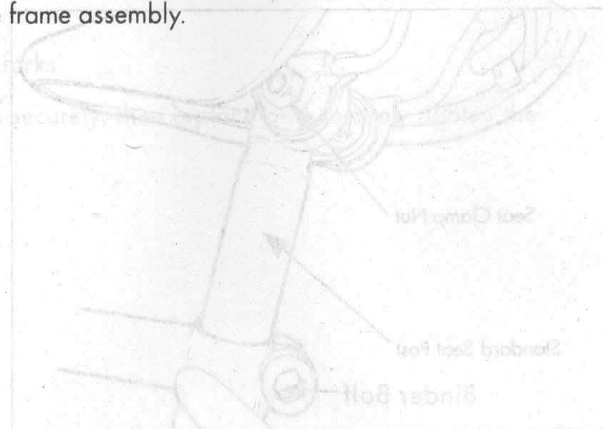

BRAKES

The correct adjustment and operation of your bicycle's brakes is extremely important for safe operation. Brakes should be checked for effective operation before every ride. Frequent checking of adjustment is necessary as the control cables will stretch and the brake pads will become worn with use.



Never ride a bicycle unless the brakes are functioning properly.

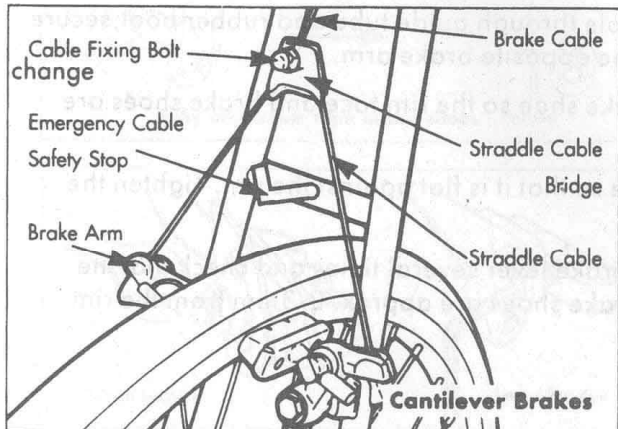
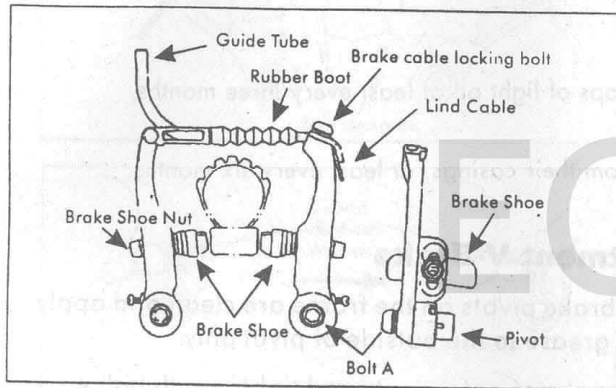

There are two types of hand operated bicycle brakes in common use; V-brake and cantilever calipers. Both utilise a handlebar mounted lever which controls a cable to operate the brake. Both V-Brake and cantilever brakes use two brake pivot arms, each mounted on separate pivots on either side of the frame/fork.

Inspection

Brake levers should be checked for tightness at least every three months. They should be set in a comfortable position within easy reach of the rider's hands, and must not be able to move on the handlebar. Some brake levers make use of a screw adjuster, which can be altered to the distance between the handlebar grip and the lever as required. The brake pads should be checked for correct positioning and tightness before every ride, and the various bolts and nuts at least every three months. Squeeze each brake lever to make sure they operate freely and that the brake pads press hard enough on the rims to stop the bike. There should be about 1.5mm - 2mm clearance between each pad and the rim when the brakes are not applied. The brake pads must be properly centred for maximum contact with the rim. Replace the brake pads if they are over worn so that the grooves or pattern can not be seen.





Some brakes have a Quick Release mechanism to allow easier wheel removal. Whenever you adjust the brakes, make sure the QR mechanism is in the closed position.



Never ride unless the Quick Release is firmly locked in the closed position.

The brake cable wires should be checked for kinks, rust, broken strands or frayed ends. The outer casing should also be checked for kinks, stretched coils and other damage. If the cables are suspect they should be replaced.

Lubrication

The brake lever and brake caliper pivot points should be oiled with 2-3 drops of light oil at least every three months, to ensure smooth operation and to reduce wear.

Cables should be greased along their entire length, after removing them from their casings, at least every six months.

Always grease new cables before fitting.

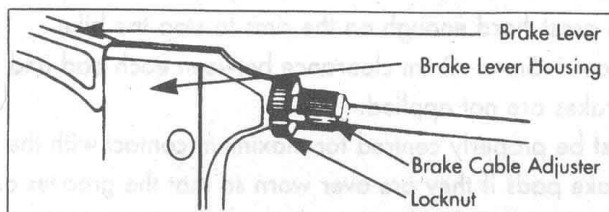
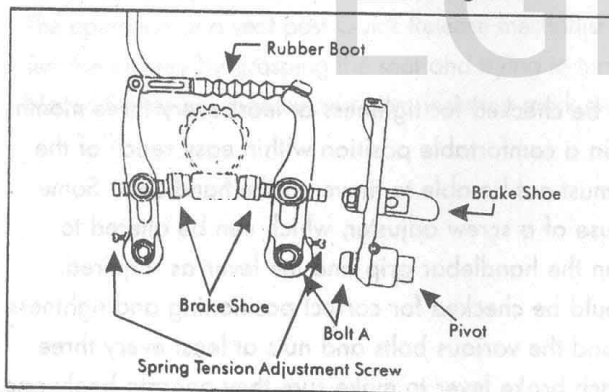

Brake Adjustment V-Brake

1. Ensure that V-brake pivots on the frame are clean and apply a light coat of grease to the outside of pivot only.
2. Place the brake arms onto pivots and tighten with bolt A.
3. Guide link cable through guide tube and rubber boot, secure with bolt on the opposite brake arm.
4. Adjust the brake shoe so the rim face and brake shoes are aligned.
5. Align the shoe so that it is flat against the rim. Tighten the nut.
6. Operate the brake lever several times and check that the front of the brake shoes are approx. 2-3mm from the rim at either side.

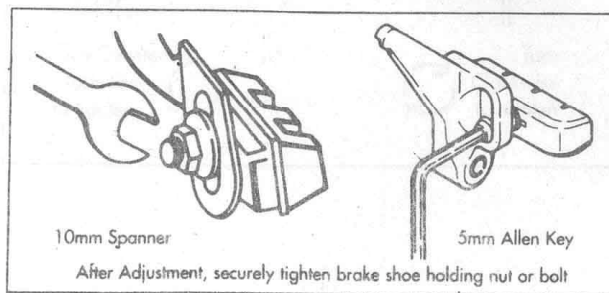
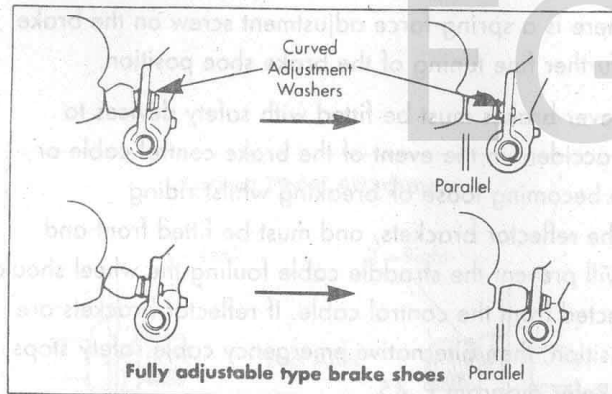
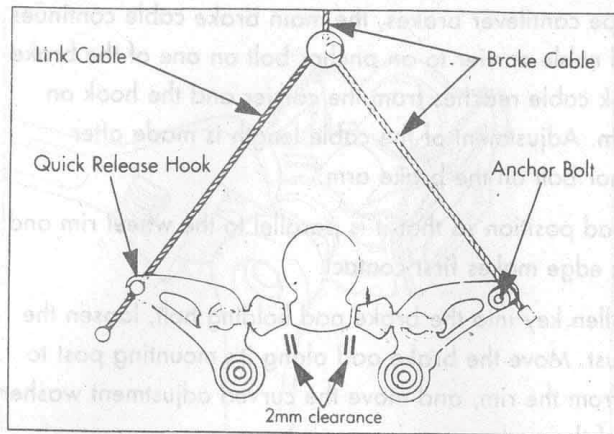

7. If either shoe fails to spring back, tension can be balanced by turning spring tension adjustment screw. Turn clockwise to add tension counter clockwise to loosen it.
8. If cable has stretched it can be tightened by winding out the barrel adjuster on the brake lever, turning anti-clockwise. For more adjustment loosen the brake cable locking bolt, Pull the cable tight then retighten the locking bolt.

Adjustment - Cantilever Calipers

Minor brake adjustment can be made via the barrel cable adjusters which are located on each brake lever. To adjust, squeeze the brake pads against the rim, loosen the lock nut, and turn the adjuster to pull the brake pads closer to, or spread them away from the rim as required.

Brake pad clearance should be a maximum 2mm from the rim. When correct re-tighten the lock nut.

If the pads cannot be set close enough to the rim in this manner, you may have to adjust either the length of the straddle cable **or** the length of the brake cable.

If the brakes use a separate brake cable and straddle cable, adjust the straddle length by first, screwing the barrel adjuster 3/4 of the way in, then loosening the straddle cable fixing bolt, then pulling or pushing the cable through the fixing bolt to adjust the length, and finally re-tightening the fixing bolt.

Check that the straddle bridge is in the middle of the cable to ensure even brake pad contact. Apply full force to the brake lever to test, then fine tune using the barrel adjuster.

To adjust the brake cable length, loosen the brake cable fixing bolt on the cable straddle bridge, adjust the length until the brake shoes are the correct distance from the rim, then re-tighten and test.



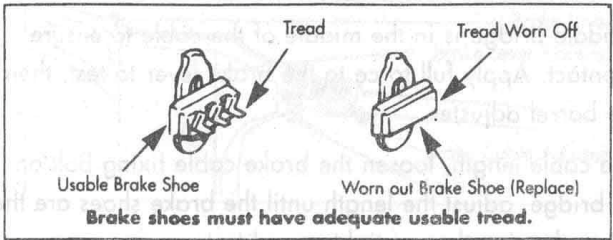
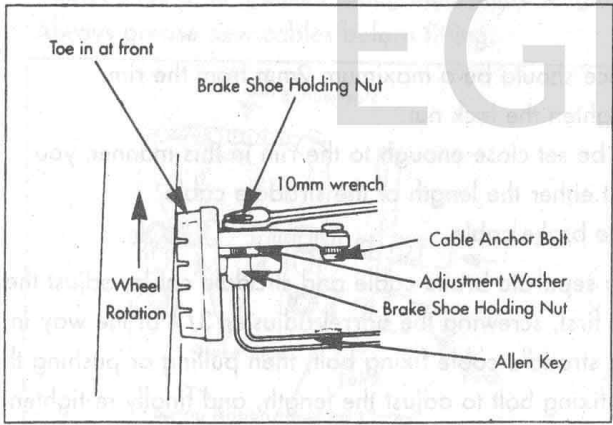
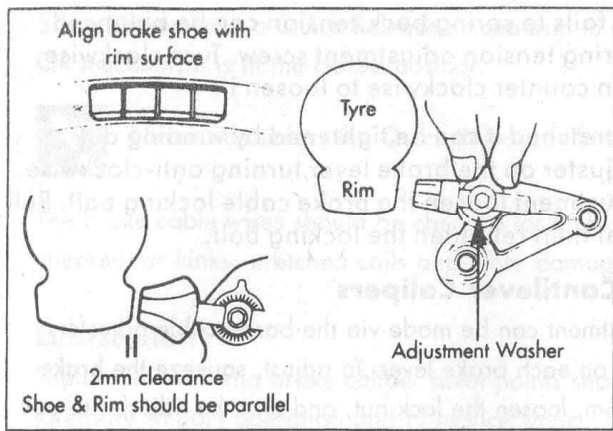

On some newer type cantilever brakes, the main brake cable continues through the central cable carrier to an anchor bolt on one of the brake arms. A shorter link cable reaches from the carrier and the hook on the other brake arm. Adjustment of the cable length is made after loosening the anchor bolt on the brake arm.

Adjust the brake pad position so that it is parallel to the wheel rim and so that the leading edge makes first contact.

To do this, fit an Allen key into the brake pad holding bolt, loosen the fixing nut and adjust. Move the brake pad along its mounting post to alter the distance from the rim, and move the curved adjustment washer to alter the angle of the pad.

On some models there is a spring-force adjustment screw on the brake arm which allows further fine tuning of the brake shoe position.

Bicycles with cantilever brakes must be fitted with safety devices to prevent a possible accident in the event of the brake control cable or the straddle bridge becoming loose or breaking whilst riding.

These are usually the reflector brackets, and must be fitted front and rear. The bracket will prevent the straddle cable fouling the wheel should it become disconnected from the control cable. If reflector brackets are not fitted in this position, then alternative emergency cable safety stops must still be fitted. Refer diagram P. 45.

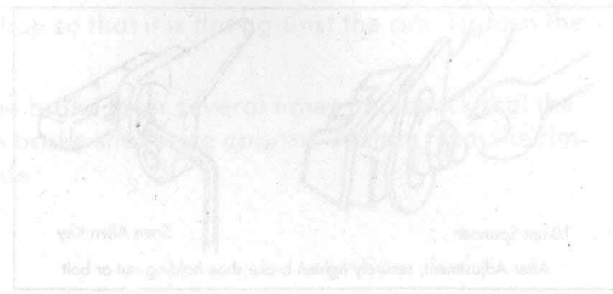

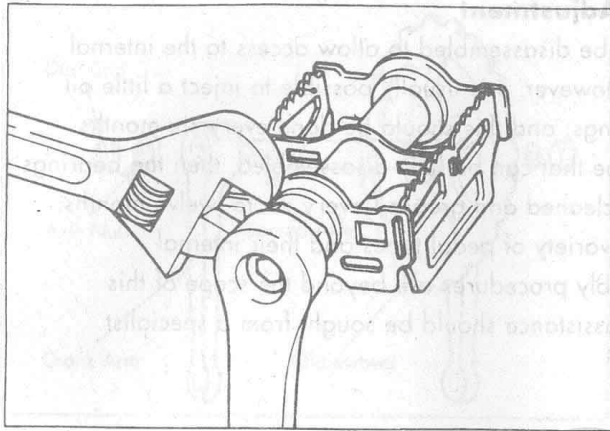

DRIVETRAIN

The drivetrain of a bicycle refers to all parts that transmit power to the rear wheel, including the pedals, chain, chainwheel and crank set, and freewheel.

Pedals

Pedals are available in a variety of shapes, sizes and materials and each are designed with particular purposes in mind. Some pedals can be fitted with toe clips and straps. These help to keep the feet correctly positioned and allow the rider to exert pulling force, as well as downward pressure, on the pedals.

Use of toe clips with straps requires practice to acquire the necessary skill to operate them with safety.



Never ride in traffic with fully tightened toe straps.

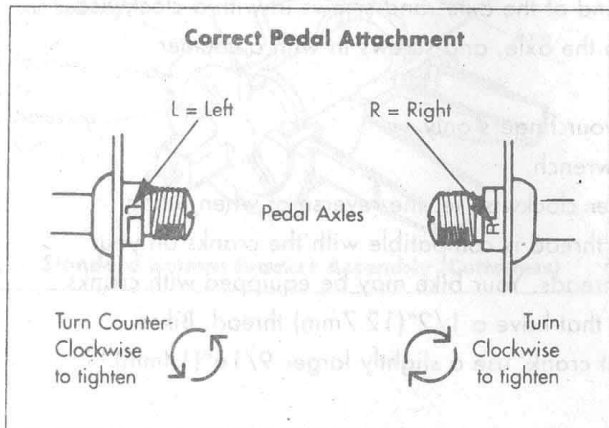

Inspection

Pedals should be inspected every month, taking note of the following areas

- Check correct tightness into the cranks. If pedals are allowed to become loose they will not only be dangerous but will also cause irreparable damage to the cranks.



Never ride with loose pedals.

- Check that pedal bearings are properly adjusted. Move the pedals up and down, and right to left, and also rotate them by hand.

If you detect any looseness or roughness in the pedal bearings then adjustment, lubrication or replacement will be required.

- Ensure front and rear pedal reflectors are clean and securely fitted.
- Ensure toe clips, if fitted, are securely tightened to the pedals.





Pedal with toe clip and strap attached

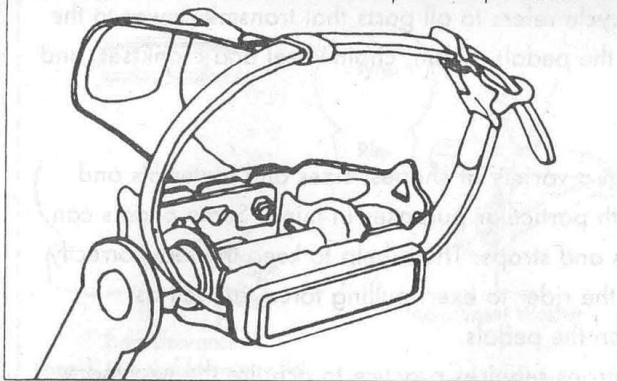

Lubrication and Adjustment

Many pedals cannot be disassembled to allow access to the internal bearings and axle. However, it is usually possible to inject a little oil onto the inside bearings, and this should be done every six months. If the pedal is the type that can be fully disassembled, then the bearings should be removed, cleaned and greased every six to twelve months. Because of the wide variety of pedal types and their internal complexity, disassembly procedures are beyond the scope of this manual and further assistance should be sought from a specialist.

Attachment

Note: The right and left pedals of a bicycle each have a different thread and are not interchangeable.

Never force a pedal into the incorrect crank arm.

The right pedal, which attaches to the chainwheel side, is marked 'R' on the end of the axle, and screws in with a clockwise thread. The left pedal, which attaches to the other crank arm, is marked 'L' on the axle, and screws in with a counter clockwise thread.

Insert the correct pedal into the crank arm and begin to turn the thread with your fingers only.

When the axle is screwed all the way in then securely tighten using a 15mm wrench.

If removing a pedal, remember that the right pedal axle must be turned counter clockwise ie. the reverse of when fitting.

If replacing the original pedals with a new set, make sure the size of the axle thread is compatible with the cranks on your bicycle. Bicycles use one of two types of cranks and these use different axle threads. Your bike may be equipped with cranks that are a one piece design with no separate axle. These operate with pedals that have a 1/2"(12.7mm) thread. Bikes equipped with three piece crank sets with a separate axle, left crank and right crank, use a slightly larger 9/16"(14mm) thread.

Note: Never try and force a pedal with the wrong thread size into a bicycle crank.

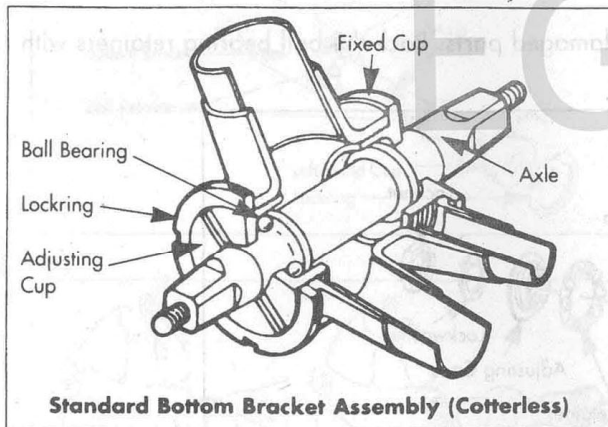
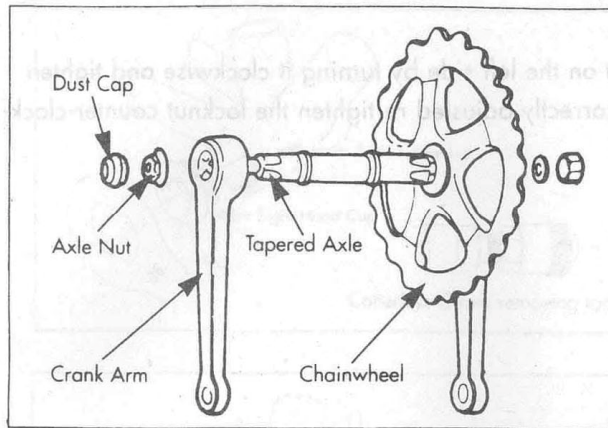

Standard Bottom Bracket Assembly (Cotterless)

Crank Set

The crank set refers to the Bottom Bracket axle and bearings, the Crank Arms and Chainrings.

Your bike may be fitted with either One Piece Cranks, where the crank arms and bottom bracket are a single component, or Cotterless Cranks, where the crank arms bolt onto the bottom bracket axle without using old fashioned type cotterpins.

The one piece system is simpler and requires less maintenance, while the cotterless system requires a little extra care.

Inspection

The crank set should be checked for correct adjustment and tightness every month. Cotterless crank axle nuts must be kept tight, and the bottom bracket bearings must be properly adjusted.

Remove the chain and try and move the cranks from side to side with your hands. The cranks should not move on the axle, and there should be only very slight movement in the bottom bracket. Next, spin the cranks. If they don't spin freely without grinding noise, then adjustment or lubrication will be needed.

Also check that there are no broken teeth on the chainrings, and wipe off excess dirt and grease that may have built up on them.



Never ride your bike if the cotterless cranks are loose. This may be dangerous and will damage the crank arms beyond repair.





Lubrication and Adjustment - One Piece Cranks

To adjust the freeplay in a one piece type bottom bracket, loosen the locknut on the left side by turning it clockwise and tighten the adjusting cone counter-clockwise using a screwdriver in the slot. When correctly adjusted re-tighten the locknut counter-clockwise.

To disassemble:

1. Remove the chain from the chainwheel.
2. Remove the left pedal by turning the spindle clockwise.
3. Remove the left side locknut by turning it clockwise and remove the keyed lockwasher.
4. Remove the adjusting cone by turning it clockwise with a screwdriver.
5. Remove the left ball retainer, slide the crank assembly out of the frame to the right, and remove the right ball retainer.

Clean and inspect all bearing surfaces and ball retainers, and replace any damaged parts. Pack the ball bearing retainers with grease, then re-assemble in the reverse of the above procedure.

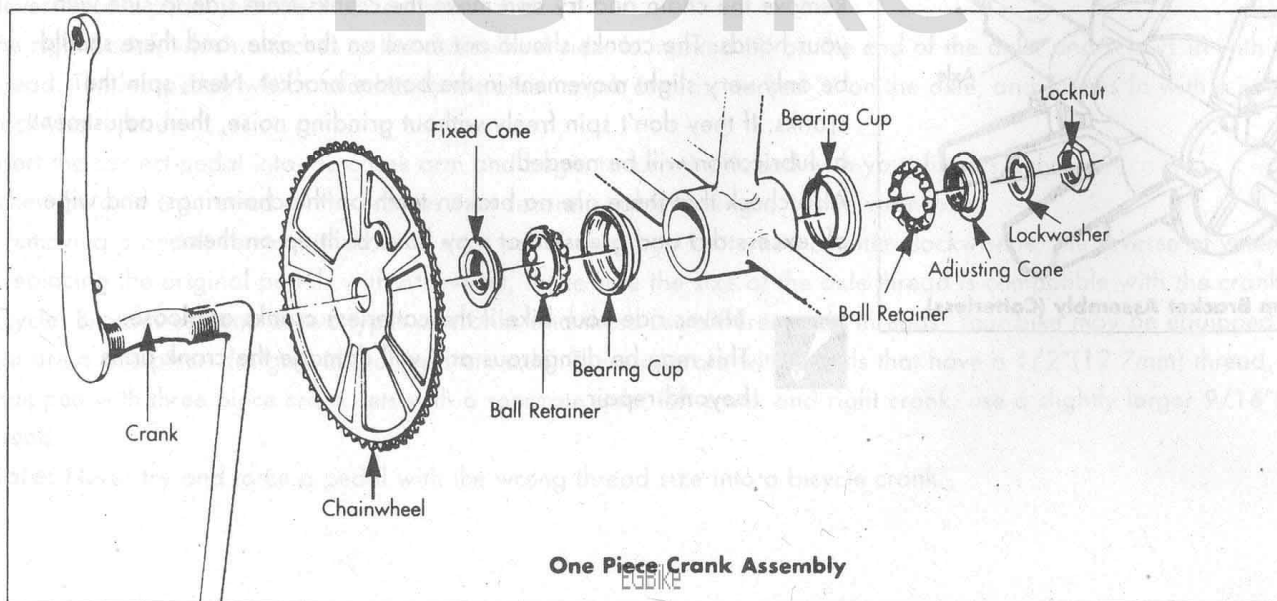

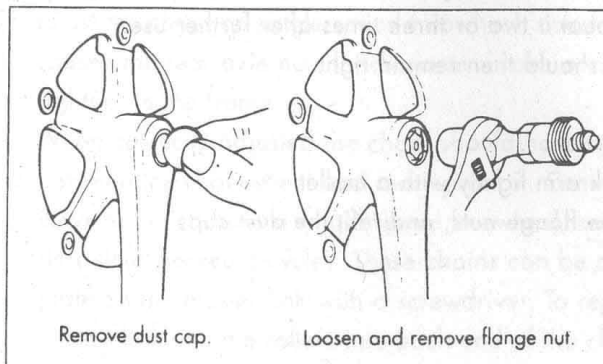
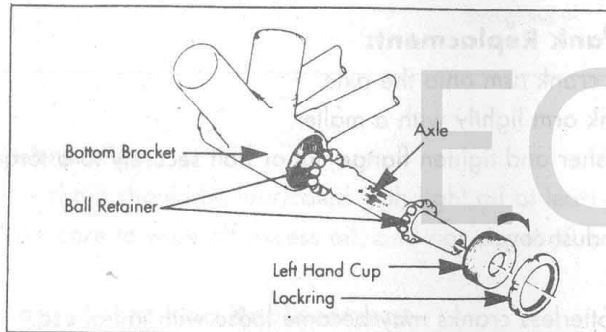
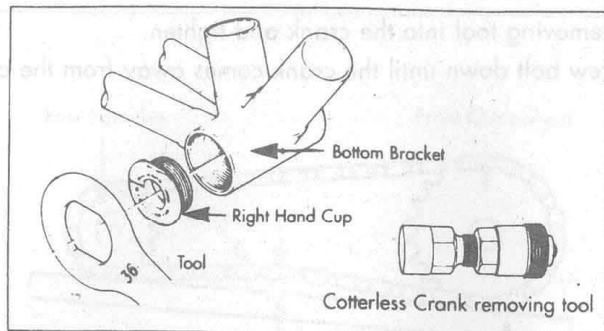

Lubrication and Adjustment - Cotterless Cranks

To adjust the freeplay in a three piece type bottom bracket, loosen the locking on the left side by turning it counter-clockwise, then turn the adjusting cup as required. Re-tighten the locking being sure not to alter the cup adjustment.

To disassemble:

1. Remove the cranks from the axle.
2. Remove the left side locking by turning it counter-clockwise.
3. Remove the adjusting cup by turning it counter-clockwise.
4. Remove the left ball retainer and slide the axle out of the frame to the left.
5. Remove the right side fixed cup by turning it counter-clockwise and remove the right ball retainer.

Clean and inspect all bearing surfaces and ball retainers, and replace any damaged parts. Pack the ball bearing retainers with grease, then re-assemble in the reverse of the above procedure.

Cotterless Crank Removal

To remove cotterless cranks use the following procedure.

Note that a special tool will be required.

1. Remove the dust cap with a coin or screwdriver.
2. Loosen the flange nut or bolt and washer, and remove.



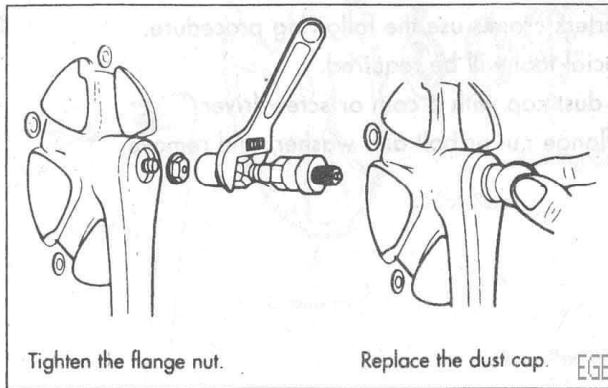
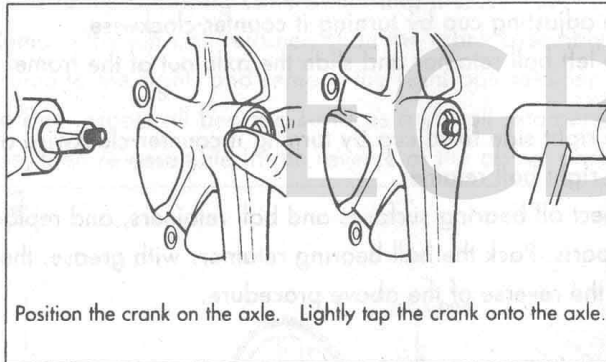
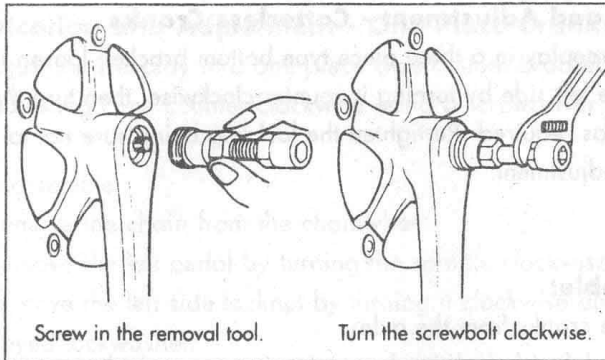

- 3 . Screw the removing tool into the crank and tighten.
- 4 . Turn the screw bolt down until the crank comes away from the axle.

Cotterless Crank Replacment:

- 1 . Replace the crank arm onto the axle.
- 2 . Tap the crank arm lightly with a mallet.
- 3 . Refit the washer and tighten flange nut or bolt securely to a torque of 27Nm.
- 4 . Replace the dust cover.

New cotterless cranks may become loose with initial use.



Perform the following task after several hours riding, and repeat it two or three times after further use.

Cranks should then remain tight.

- 1 . Remove dust cap.
- 2 . Tap the crank arm lightly with a mallet.
- 3 . Re-tighten the flange nuts, and refit the dust caps.

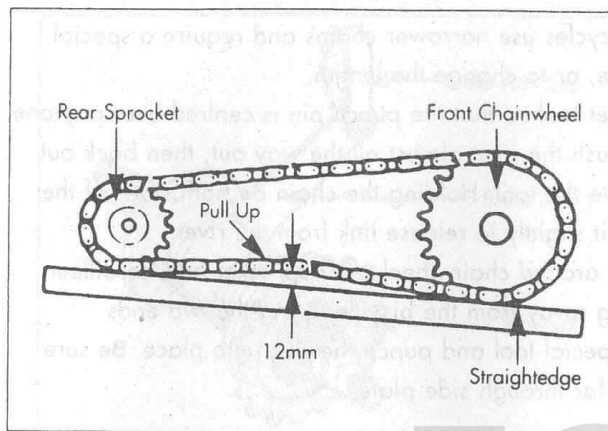

Chain

Inspection

The chain must be kept clean, rust free and frequently lubricated in order to extend its life as long as possible. It will require replacing if it stretches, breaks or causes inefficient gear shifting. Make sure that there are no stiff links, they must all move freely.

Lubrication

The chain should be lubricated with light oil at least every month, or after use in wet, muddy, or dusty conditions. Take care to wipe off excess oil, and not to get oil on the tyres or rim braking surfaces.

Adjustment and Replacement

On derailleur geared bicycles the rear derailleur automatically tensions the chain.

To adjust the chain on single speed freewheel, coaster hub braked or 3-speed hub geared bicycles:

1. Loosen the rear axle nuts (and coaster brake arm clip if fitted) and move the wheel forward, to loosen, or backward, to tighten, in the frame.
 2. When correctly adjusted the chain should have approximately 10mm of vertical movement when checked in the centre between the chainwheel and rear sprocket. Centre the wheel in the frame and re-tighten the axle nuts after any adjustment.
- Bicycles which have a single speed freewheel, coaster hub brake or 3-speed hub, generally use a wider type chain than derailleur geared bicycles. These chains can be disconnected by way of a special joining link after prising off a U-shape plate on the master link with a screwdriver. To replace, feed the chain around the chainwheel and rear sprocket, fit the master link into the rollers into each end of the chain, position the master link side plate, and slip on the U-shaped snap-on plate. Make sure the open end of the U-shaped plate is trailing as the link approaches the chainwheel when pedalling forward.

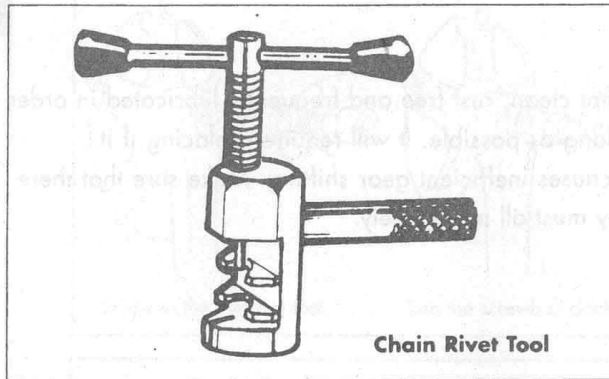

Chain Rivet Tool

Derailleur geared bicycles use narrower chains and require a special tool to fit and remove, or to change the length.

To remove, fit the rivet tool so that the punch pin is centred over any one of the chain rivets. Push the rivet almost all the way out, then back out the punch and remove the tool. Holding the chain on both sides of the punched rivet, bend it slightly to release link from the rivet.

To install, feed chain around chainwheel, rear sprocket and derailleur cage with rivet facing away from the bicycle. Bring the two ends together within the special tool and punch the rivet into place. Be sure not to push rivet too far through side plate.

Freewheel

Inspection

Like the chain, the freewheel must be kept clean and well lubricated. If the chain has become worn and needs replacing, then it is likely that the freewheel will also have become worn and should also be replaced.

Take the chain off the freewheel and rotate it with your hand. If you hear a grinding noise or the freewheel stops suddenly after spinning it, it may need adjustment or replacement. Such action is beyond the scope of this manual and you should consult a specialist dealer.

Lubrication

Remove any accumulated dirt from the freewheel with a brush and some kerosene. Disassembly of the free wheel is a complicated procedure requiring special tools, and should be left to a specialist dealer. Apply oil to the freewheel whenever you lubricate the chain, taking care to wipe off any excess.

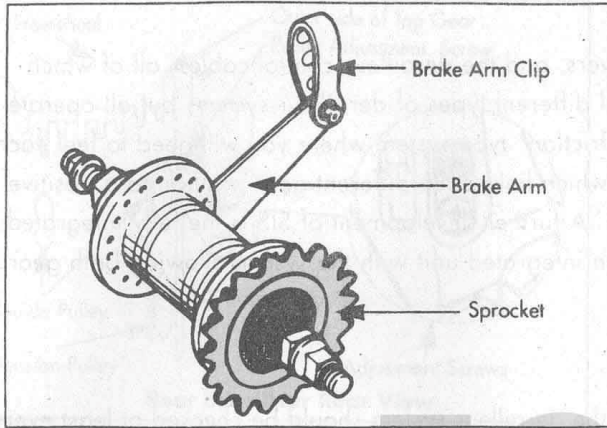

Coaster Hub

Many BMX style and other children's bicycles are fitted with a Coaster Hub Brake in the rear wheel. This type of brake offers the advantages of reliability and easy operation. The brake is operated by applying back pedal pressure and allows the rider to "coast" without pedalling if desired.

There are several models of coaster hubs available, and the internal mechanisms are very complex. They require infrequent attention as far as lubrication, adjustment or replacement of internal parts, but this should be left to a specialist if needed.

Keep the coaster hub sprocket clean and oil it along with the chain.



Make sure the brake arm is correctly attached to the chainstay with the brake arm clip. The brake will not operate otherwise.





DERAILLEUR SYSTEMS

The derailleur system comprises the front and rear derailleurs, the shift levers, and the derailleur control cables, all of which must function correctly for smooth gear shifting to occur. There are several different types of derailleur systems but all operate using similar principles. Your new bicycle may be fitted with a standard "friction" type system where you will need to feel each gear shift into position. It may be fitted with an "index" system (e.g. SIS) which links each different gear position to a positive click mechanism in the shifter, and makes shifting very simple and precise. A further development of SIS is the fully integrated system (e.g. STI) where the shift lever and brake lever mechanisms form an integrated unit with the system allowing both gear shifting and braking to occur at the same time.

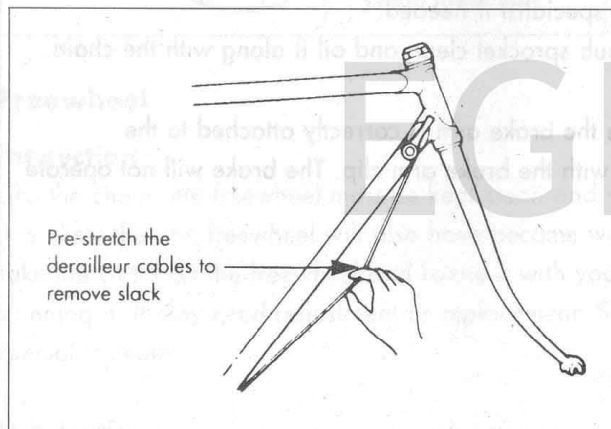

Inspection

The operation of the derailleur system should be checked at least every month. Check the operation of the rear derailleur first, then the front. The rear derailleur should shift the chain cleanly from one cog to the next without hesitation. On SIS equipped bicycles, each notched position in the shifter must equate to a new gear position. After shifting, the rear derailleur should not rub on the chain. The derailleur should never cause the chain to fall off the inner or outer freewheel cogs.

The front derailleur should also shift the chain cleanly and without hesitation between each chainring. If your bicycle is equipped with front SIS, then each click or stop in the shifter should equate exactly to a new gear position. When the chain has been positioned onto a new chainring, it should not rub on the front derailleur. The chain should not fall off a chainring at any time.

Derailleur control cables are a critical component that must be well maintained for accurate shifting performance. Check them for any sign of rust, fraying, kinks, broken strands, and any damage to the cable housing. If you find any problems, the cables may need replacing before you next ride.

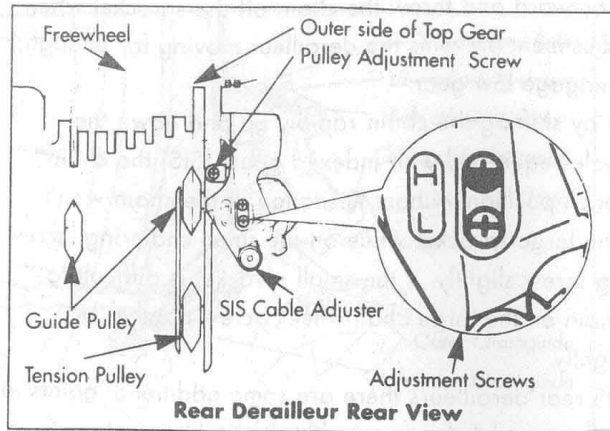

Lubrication

All the pivoting points of the front and rear derailleurs should be lubricated with light oil at least every month. Be sure to wipe off any excess oil to prevent attraction of dirt into the mechanisms.

The shifting cables should be cleaned and re-coated with a thin layer of grease every six months, or whenever new cables are being installed.

Adjustment - Rear Derailleur

Find a way to lift the back wheel of your bicycle off the ground so you can turn the pedals forward. Shift the chain to the smallest rear cog and the largest front chainwheel, and loosen the cable fixing bolt.

Position yourself behind the bike so you can easily check the alignment of the chain, rear sprockets, and derailleur pulleys.

To adjust high gear, turn the adjustment screw marked 'H' until the top guide pulley lines up with the outside edge of the outermost sprocket.

If the position of the guide pulley is set beyond the outside edge of the sprocket, the chain will come off when pedalling. If the guide pulley is set too far toward the larger cogs, the chain wheel may not shift onto the small sprocket. Re-tighten the cable fixing bolt.

At this point the cable must be checked and adjusted to eliminate slackness with the right shifter all the way to the low position (fully forward for downtube shifters, fully back on MTB top bar shifters). If there is too much slack, loosen the cable fixing bolt, pull the cable taut, and re-tighten the bolt.

To adjust low gear, turn the adjustment screw marked 'L' far enough counter-clockwise so that you can shift the chain onto the largest rear sprocket and the smallest chainring. Move the shifter until the derailleur guide pulley and the sprocket are aligned. Turn the 'L' adjustment screw until it meets resistance. If the screw is turned in too far it will allow the



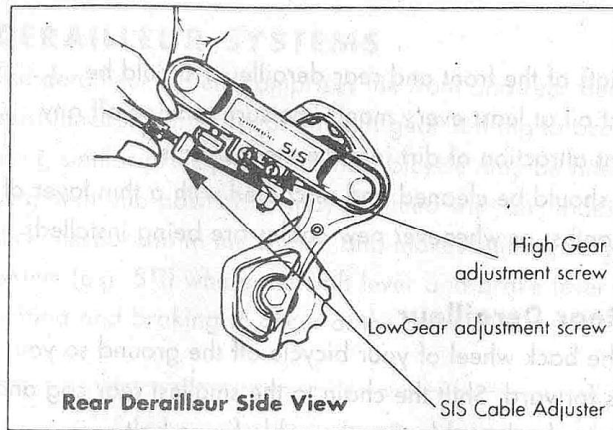

Rear Derailleur Side View

derailleur to move outward and throw the chain off the sprocket when pedalling. If the adjustment prevents the derailleur moving far enough, the chain may not engage low gear.

Test the adjustment by shifting the chain rapidly up and down the freewheel. On bicycles equipped with indexed gears (SIS) the chain should move into each position without hesitation. If the chain won't move easily onto the large sprocket while on the small chainring, screw out the 'L' adjusting screw slightly. If the small sprocket is difficult to engage with the chain on the large chainwheel, screw out the 'H' adjusting screw slightly.

When adjusting SIS rear derailleurs there are some additional points to attend. Some derailleur models have an additional adjustment screw to set the guide pulley as close as possible to the sprocket. This is adjusted with the chain on the small cog and when set there must be no hint of rubbing noise or fouling when pedalling in reverse.

To fine tune the SIS adjustment, make sure the shift lever is set on SIS mode and shift the chain from top to second gear. If the chain will not move to the second gear, turn the cable adjusting barrel counter-clockwise to increase the cable tension. If the chain moves past the second gear, turn the adjuster clockwise to decrease the tension.

Next, pedal the cranks and with the chain still in second gear, turn the adjuster counter-clockwise to increase the inner cable tension.

Stop turning the adjuster just before the chain makes noise against the third gear. This completes the adjustment.

After a period of use, the derailleur cable will stretch and you may find difficulty shifting the chain to the large freewheel cog or the large chainwheel. If this occurs, re-adjust the cable either with the barrel adjuster or by repeating the above procedures.

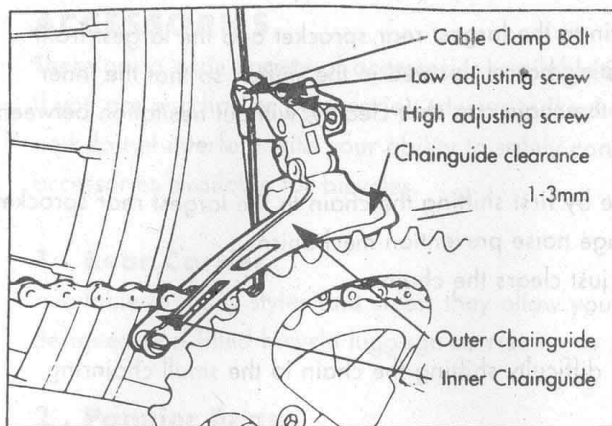

Adjustment - Front Derailleur

The front derailleur must be positioned so that its chain guides are parallel to the chainrings. The outer chain guide should have a clearance of about 2-4mm above the large chainring when directly over it. Alter the derailleur position after loosening the clamp bolt.

To adjust low gear, shift the chain onto the smallest front chainring and the largest rear sprocket, and loosen off the control cable fixing bolt. Turn the adjusting screw marked 'L' until the inner cage just clears the chain.

With the shift lever fully in the low position, pull the control cable taut and re-tighten the cable fixing bolt.

To adjust high gear, shift the chain to engage the smallest rear sprocket, and turn the adjusting screw marked 'H' so that the chain can be shifted to the largest chainring. Position the derailleur so that the inside of the outer cage just clears the chain by turning the 'H' adjusting screw further.

Test the gears in all possible front and rear chain positions. If the chain rubs against the cage when on the inner or outer chainring in any rear sprocket position, then turn the appropriate adjusting screw counter-clockwise. If the chain falls off either the inner or outer chainring, turn the appropriate adjusting screw clockwise. If the chain will not shift onto either the inner or outer chainring, turn the appropriate adjusting screw counter-clockwise.





To fine tune the adjustment on MTB bicycles fitted with front SIS, shift the chain to the largest rear sprocket and the largest front chainring. Shift from the largest to the middle chainring. Turn the cable adjusting barrel, located in the shifter, so that the inner chainguide just clears the chain. This should complete the adjustment so that the chain can shift cleanly, without hesitation between each chainring.

Fine tuning on racing style bicycles fitted with dual control (STI) levers is done by first shifting the chain to the largest rear sprocket and the largest chainring. Next, push the left hand inner lever lightly to engage noise prevention mechanism. Then turn the downtube mounted cable adjuster so that the inner chainguide just clears the chain. This completes the adjustment.

After a period of use, the front derailleur cable will stretch and you may find difficulty shifting the chain to the small chainring. If this occurs, loosen the cable fixing bolt and re-tension the cable.

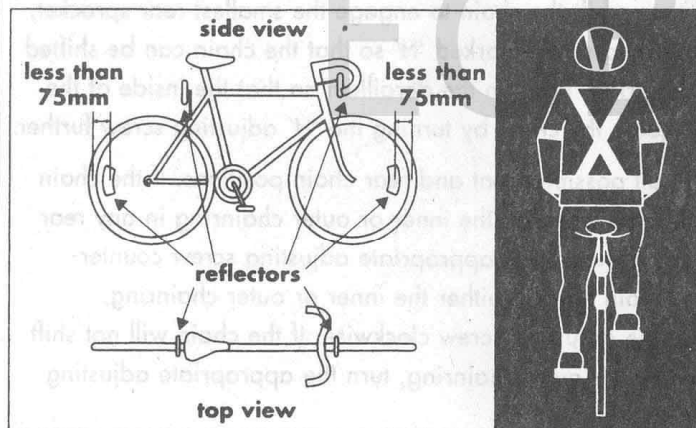

REFLECTORS

Your bicycle is supplied with one red (rear), and two orange (wheel) reflectors. In addition each pedal has two orange reflectors.

These are an important safety and legal requirement, and they should remain securely fitted and in good, clean condition at all times.

Front and rear reflectors should be aligned vertically, and wheel reflectors should be fixed opposite the valve within 75mm of the rim. Reflectors should always be used in conjunction with powered lighting when riding at night. Reflective tape on your clothing is also suggested to increase rider visibility at night.

ACCESSORIES

There are a wide variety of accessories available that can enhance your bicycle's function, safety, versatility and style. If you are purchasing accessories, always make sure they are suitable for your bicycle. Be sure that they are correctly fitted and do not interfere with your ability to safely control your bicycle. Following is a list of some of the many kinds of accessories available for bicycles.

1 . Rear Carrier

Available in many styles and sizes, they allow you to safely carry your luggage. Luggage should only be carried on a properly designed and fitted bicycle luggage carrier.

2 . Pannier Bags

Versatile carry bags that usually fit either side of a rear mounted carrier. Several weather resistant compartments make them very useful for bicycle touring when you need to carry extra gear and keep it dry.

3 . Saddle Bag

These are useful for carrying small items such as tools, a spare tube or a puncture kit. Other small bags available are designed to fit on the handlebars, or in the corner of the main frame where they double as a shoulder pad if carrying the bicycle.

4 . Child Safety Carrier

The only way to carry children up to approximately 18kg in weight is in a properly designed carry seat.

These should be firmly attached to the bicycle, be fitted with a restraining harness, support the child and not allow access to the spokes of the turning rear wheel.

5 . Lights

Bicycle lights should always be used when riding at night or in other low light conditions. There are many kinds available. Some are powered by a dynamo generator, others are battery operated and are able to operate while the bicycle is not moving. Battery powered lights are often easily removable and front lights can double as a flashlight. Front lights must have a white beam. Rear lights must have a red beam; they often have a flashing mode which makes them highly visible to other road users. Lights should always be used in conjunction with your bicycle's fitted reflectors. Before riding make sure batteries are properly charged and dynamo power cables are properly connected.





6 . Safety Flag

Usually available in bright fluoro colours, these attach to the rear axle and make you more visible when riding in traffic.

7 . Pump

Essential for maintaining your tyres at their correct pressure. Make sure the end connection is the same as valves on your bicycle's tubes.

8 . Repair Kit

You'll need one of these to help get you mobile again in the event of a tyre puncture.

9 . Lock

Your new bicycle is an expensive item which you would not like to lose through theft. There are many kinds of bicycle locks available, some more effective than others. Always lock your bicycle to an immovable object if you leave it unattended.

10 . Rear View Mirror

A very useful item to keep you aware of traffic moving behind you.

11 . Bar Ends

These can be attached to the ends of Mountain Bicycle handlebars to give you added flexibility in hand positioning, especially when hill climbing.

12 . Computer

Better than a simple speedometer, bicycle computers come with a number of functions so you can measure your speed, distance travelled and time. They are a very useful aid for fitness training.

13 . Mudguards

Prevent road dirt and water from soiling your clothes and getting in your eyes.

1. Water Bottles

When riding in hot weather you'll need to increase your body's liquid intake. Bicycle water bottles are available in attractive fashion colours in various sizes and are conveniently carried in frame mounted carry cages.

15. Gloves

Bicycle gloves help prevent soreness and blisters on your hands during long rides and also give protection in the event of a fall. They are available in a variety of great looking fashion colours and designs.



EGBike



TROUBLESHOOTING

Problem	Possible Cause	Remedy
Gear shifts not working properly	Derailleur cables sticking/stretched/damaged Front or rear derailleur not adjusted properly Indexed shifting not adjusted properly	Lubricate/tighten/replace cables Adjust derailleurs Adjust indexing
Slipping chain	Excessively worn/chipped chainring or freewheel sprocket teeth Chain worn/stretched Stiff link in chain Non compatible chain/chainring/freewheel	Replace chainring, sprockets and chain Replace chain Lubricate or replace link Seek advice at a bicycle shop
Chain jumping off freewheel sprocket or chainring	Chainring out of true Chainring loose Chainring teeth bent or broken Rear or front derailleur side-to-side travel out of adjustment	Re-true if possible, or replace Tighten mounting bolts Repair or replace chainring/set Adjust derailleur travel
Constant clicking noises when pedalling	Stiff chain link Loose pedal axle/bearings Loose bottom bracket axle/bearings Bent bottom bracket or pedal axle Loosen crankset	Lubricate chain Adjust bearings/axle nut Adjust bottom bracket Replace bottom bracket axle or pedals Tighten crank bolts
Grinding noise when pedalling	Pedal bearings too tight Bottom bracket bearings too tight Chain fouling derailleurs Derailleur jockey wheels dirty/binding	Adjust bearings Adjust bearings Adjust chain line Clean and lubricate jockey wheels

Problem	Possible Cause	Remedy
Freewheel does not freewheel	Freewheel internal pawl pins are jammed	Lubricate. If problem persists, replace freewheel
Brakes not working effectively	<ul style="list-style-type: none"> Brake blocks worn down Brake blocks/rim greasy, wet or dirty Brake cables are binding/stretched/damaged Brake levers are binding Brakes out of adjustment 	<ul style="list-style-type: none"> Replace brake blocks Clean blocks and rim Clean/adjust/replace cables Adjust brake levers Centre brakes
When applying the brakes they squeal/squeak	<ul style="list-style-type: none"> Brake blocks worn down Brake block toe-in incorrect Brake blocks/rim dirty or wet Brake arms loose 	<ul style="list-style-type: none"> Replace blocks Correct block toe-in Clean blocks and rim Tighten mounting bolts
Knocking or shuddering when applying brakes	<ul style="list-style-type: none"> Bulge in the rim or rim out of true Brake mounting bolts loose Brakes out of adjustment Forks loose in head tube 	<ul style="list-style-type: none"> True wheel or take to a bike shop for repair Tighten bolts Centre brakes and/or adjust brake block toe-in Tighten headset
Wobbling wheel	<ul style="list-style-type: none"> Axle broken Wheel out of true Hub cones loose Headset binding Hub bearings collapsed 	<ul style="list-style-type: none"> Replace axle True wheel Adjust hub bearings Adjust headset Replace bearings





Problem	Possible Cause	Remedy
Steering not accurate	Wheels not aligned in frame Headset loose or binding Front forks or frame bent	Align wheels correctly Adjust/tighten headset Take bike to a bike shop for frame realignment
Frequent punctures	Inner tube old or faulty Tyre tread/casing worn Tyre unsuited to rim Tyre not checked after previous puncture Tyre pressure too low Spoke protruding into rim	Replace inner tube Replace tyre Replace with correct tyre Remove sharp object embedded in tyre Correct tyre pressure File down spoke

EGBike

Purchase Record Card

Fill in immediately and retain as a record of your purchase!

Owners Name:

Address:

Date Purchased:

Place of Purchase:

Brand:

Model Name:

Wheel Size:

Colour:

Serial Number:

Serial Number Possible Locations

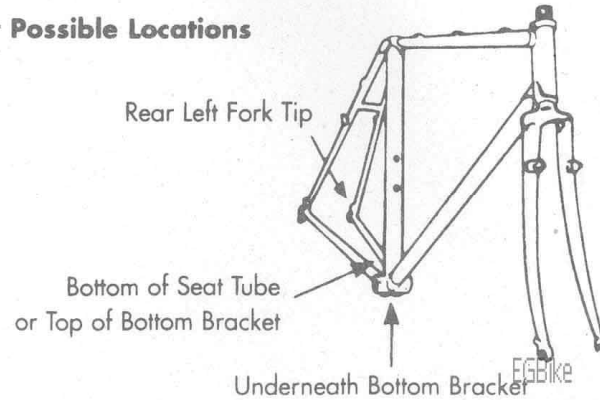

WARNING

1. Handlebar grips or End plugs

Should be replaced if damaged, as bar tube ends have been known to cause injury. It is important for children's bikes to be checked regularly to ensure adequate protection for the ends of the handlebars is in place.

2. Forks

If replaced they must have the same rake and same cube inner diameter as those originally fitted to the bicycle.